



# TIMBER TIMES

On the Web at: <http://www.woodcny.org>

On Facebook – WoodCNY

Volume 6, Issue 2

February 2023

The Woodworkers of Central New York is a Chapter of the [American Association of Woodturners](#)

## FEBRUARY EVENTS

**Wednesday, February 1<sup>st</sup>**  
**@6:30pm**  
**Woodworking SIG Demo**  
**Air Brushing** w/Jackie Yonkers  
**In Person** @ Station 1, Belgium  
Cold Springs Fire Dept, 7920  
River Rd, B'ville or **Via Zoom**

**Friday to Sunday, Feb 10-12**  
**Woodworking EXPO at NYS**  
**Fairgrounds (see right)**

**Tuesday, February 14<sup>th</sup>**  
**@6:30pm**  
**Turning SIG Demo**  
**Tool Fundamentals** with  
Robert Love, Charlie LaPrease  
& Larry Prunotto  
**In Person** @ Station 1, Belgium  
Cold Springs Fire Dept, 7920  
River Rd, B'ville or **Via Zoom**

**Wednesday, February 15<sup>th</sup>**  
**@6:30pm**  
**Scrolling SIG Demo**  
**Intarsia** with Sherry Kelsey  
**In Person** @ Eight Acres  
(Baldwinsville) or **Via Zoom**

**Thursday, February 16<sup>th</sup>**  
**Carving SIG Workshop**  
**Carving a Heart w/Arrow Part**  
**2** with Gary Morison  
Gathering Starts at **5pm**  
Open Carving Until **8:15pm**  
**In Person** at Beaver Lake  
Nature Center, 8477 East Mud  
Lake Road, Baldwinsville

**Saturday, February 18<sup>th</sup> 9am -**  
**noon**  
**Turning Workshop** at Eight  
Acres Event Center, B'ville  
Exact address available to  
members and potential visitors by  
email to [woodcny@gmail.com](mailto:woodcny@gmail.com)

**Thurs, February 23 thru Sat,**  
**February 25 8:30am-4pm**  
**Demo @ NYS Farm Show**  
**In Person** at Witter Museum on  
NYS Fairgrounds

## FEBRUARY 2023 IS A BUSY MONTH!

Club members will be very busy in February 2023. In addition to normal SIG meetings, we have our traditional demos at the NYS Farm Show and now the Woodworking Expo. Here are some details.

### Woodworking Expo

**Who?** This is the link – [www.wwexpo.com](http://www.wwexpo.com)

**When?** Friday, February 10 – 12noon to 6pm  
Saturday, February 11 – 10am to 6pm  
Sunday, February 12 – 10am to 4pm

**Where?** Horticulture Building at NYS Fairgrounds

**What Will the Club Have There?** We're looking for 3 contiguous booth spaces with electricity and table. Club members can bring a hand plane and scrollsaw with some supplies. We will also have a table for a demo.

**How Do I Sign Up?** [www.wwexpo.com](http://www.wwexpo.com) with the times you want to do. I plan to do a demo (i.e. carve, scroll, etc.). Plan to bring their own tools and bring their own chairs for a comfy chair.

**Why Such Late?** The week of January 9<sup>th</sup>.

**What Vendors?** We're working on getting vendors. We have no control over the vendors. As a club, we will be represented.

**Why Haven't I Seen Advertising for the Event?** We don't understand that either.

**Will Poor Attendance Mean They Won't Come Back?** We've already raised that question with them.

**CANCELLED BY PROMOTER**



### New York State Farm Show

**When?** Thurs–Saturday, February 23-25 – 8:30am to 4pm

**What?** This is the leading farm show in the Northeast and it takes over 7 buildings at the NYS Fairgrounds.

**How Are We Involved?** We demonstrate woodworking in the Witter Agricultural Museum, our home for demos during the NYS Fair. We've done those demos for 20+ years. We have a large area and are an integral part of the Museum's demonstrators.



Continued on Page 2

## INSIDE THIS ISSUE

February is a Busy Month Woodworking Expo Demos NYS Farm Show Demos	1 & 2
February 2023 Events	3-4
Club Workshop Info	4
Mike's Corner – Let's Make an Ice Cream Scoop	5
Upcoming Training–Wood Burning	8
Woodburning Information	6-9
Wood Education–Explain Poplar	10
Beads of Courage Boxes	11
Girl Scout Badge	12
<i>Shop Time</i> Sled for Cutting Odd Shaped Wood Glue Top Popper	13
<i>More Shop Time</i> Simple Bowl Depth Guide Penny Pinching Glue Spreader Half Pencil Marks Exact Copies	14
Membership / Membership Badges	14
Show & Tell January 2023	15- 20
Club Exhibit at Baldwinsville Library	21- 22
January 2023 Workshop	23
Corporation & Leadership Information	24
NWA's Showcase & Totally Turning	25
Updates	25
Now Is the Time!	26
Location of Meetings	27
Sending Photos	27
Finding Equipment Locally	27
Corporation Supplies, etc.	28
Sharpening Services	28
American Association of Woodturners Info	29
In-Person Classes	29
Classes, Events & Symposiums	30
Directions to Locations	31
Meeting Schedules	32-3
Classifieds	34
Area Lumber Suppliers	34

## FEBRUARY BIG EVENTS, PAGE 2



*The Farm Show Display in 2022*

**Why the Farm Show?** A different group of people, especially farmers, attend the Farm Show. One of the club's missions is to educate the public about woodworking. We do so and as usual have FUN doing so! And, woodworking was (and is) a big part of the farms.

**Where?** Daniel Parrish Witter Agricultural Museum at NYS Fairgrounds. This building sits just south of the Coliseum along what is called Restaurant Row during the Fair. It is a great stopping place for attendees between the Expo Center and the Dairy Cattle Building.

**What Will the Club Have There?** Unlike our demonstrations during the NYS Fair, we can use electrified tools during the Farm Show. There will be 2 lathes and the club scrollsaw. Our workbench will be there along with the work surfaces and such that are there during the Fair. And, there is plenty of room for us. We are the only ones in the center room. Carvers should bring their comfy chairs. There is a space for displaying your projects.

**Where Do I Park?** *No walking from the Gray lot!* We can park right by the building so bringing tools in is easy. As you arrive, you just tell the parking attendants who try to direct you to attendee parking that you are working at the Museum. A map will be provided prior to the event for everyone.

**Any Downsides?** There is no water in the building so you have to go to the Expo or Dairy Building to use a restroom. We have badges that get you in free. Otherwise, it can be cold but there is heat in the building, we just encourage you to dress in layers.

**What Can I Do to Help?** We need people to demonstrate their crafts. We need people to help transport equipment & supplies on Wednesday the 22<sup>nd</sup> and on Saturday afternoon afterwards as well as to help setup & pack up..

**How Do I Volunteer?** If you have not done so already, send an email to [woodcny@gmail.com](mailto:woodcny@gmail.com) with the times you want to help and what you plan to do (i.e. carve, scroll, turn, hand work—what are you going to build, etc.?). The list will be available at all February events but we would ask that you sign-up by **end of day, Sunday, February 19<sup>th</sup>**. Plan to bring what you need or will work on. If you need something special brought, you need to let us know ahead of time. Carvers should bring their comfy chairs.

**What Then?** There will be further communications via email with volunteers so make sure [woodcny@gmail.com](mailto:woodcny@gmail.com) is an approved mail source.

## UPCOMING EVENTS

### WOODWORKING SIG BASICS OF AIR BRUSHING WEDNESDAY, FEBRUARY 1<sup>ST</sup>—6:30PM

There are many ways you can go about painting a surface. One of the most interesting means is by using a technique called air brushing. There are very specific techniques and equipment used in air brushing. We've enlisted one of our member artists, **Jackie Yonkers**, to share her knowledge of this topic. Jackie will talk about the equipment needed (what are better units versus junk), the paints that can be used, as well as any special mediums that can be used. She will also demonstrate the technique.

This session will be available as a hybrid session—both in-person and via Zoom. We hope many of you will join us in-person, handle your membership renewal, and bring your *Show & Tell* items. All members will receive a reminder with the Zoom link a few days before the event. Can't make it or viewing via Zoom but have projects to show? Send an email with photos and a description to [woodcny@gmail.com](mailto:woodcny@gmail.com) by 3pm on February 1<sup>st</sup> to be included in the slide show! Earlier is very much appreciated!

### TURNING SIG TOOL FUNDAMENTALS TUESDAY, FEBRUARY 14<sup>TH</sup>—6:30PM

Schedule your Valentine's Day celebration on a less busy night so you don't miss this great talk and demonstration on tool fundamentals for the turner! Three long-term turners will review the basic tools you should use on projects, how to work with them, how they should be sharpened for maximum control and cutting, and what you shouldn't do with the tools. Plan to join the demonstrators, Robert Love, Larry Prunotto, & Charlie LaPrease for an evening that will likely include many laughs as well. You can practice your skills on the Saturday following, February 15<sup>th</sup> at the club workshop.

**Returning At This Meeting – The Monthly Challenge!** Anyone who attends this session, can enter their tree or snowman created after the January 10<sup>th</sup> demo in the Challenge. Attendees will vote during the break for their *People's Choice* recipient who will receive a gift card. Another *Challenge Participant* will also receive a gift card.

This session will be available as a hybrid session—both in-person and via Zoom. We hope many of you will join us in-person, handle your membership renewal, and bring your *Show & Tell* items. All members will receive a reminder with the Zoom link a few days before the event. Can't make it or viewing via Zoom but have projects to show? Send an email with photos and a description to [woodcny@gmail.com](mailto:woodcny@gmail.com) by 3pm on February 14<sup>th</sup> to be included in the slide show! Earlier is very much appreciated!

### TOOL RAFFLES RETURN

Our popular tool raffles return in February. Our first raffle will run for 3 months and it is for an Earlex Spray Station HV5500. Tickets are \$1 each and 6 for \$5.



**ALWAYS  
CHECK THE  
WEBSITE FOR  
THE LATEST  
EVENT INFO**



**CHALLENGE**

**Raffle**







## SCROLLERS SIG — INTARSIA WEDNESDAY, FEBRUARY 15—6:30PM

The Scrolling SIG will meet on Wednesday, February 15<sup>th</sup> to talk about *Intarsia Basics* with Sherry Kelsey. Bring your *Show & Tell* and your segmentation project(s). Have items to show but not able to attend? Send photos and descriptions by 3pm on the 15<sup>th</sup> to [woodcny@gmail.com](mailto:woodcny@gmail.com) to have your projects included in the slide show (earlier preferred).

For now, the Scrollers will meet in-person in the Eight Acres Shop and via Zoom. The address will be provided via email along with the Zoom link.

## CARVERS SIG — CARVING A HEART THURSDAY, FEBRUARY 16—5-8PM

The Carving SIG will meeting on Thursday, February 16<sup>th</sup> (In-person only) Gathering will start at 5pm. During this session, Gary Morison will work with people to continuing carving the heart shown in the photo. Don't forget your *Show & Tell* items also.

The Carvers meet in the large Community Room at the *Beaver Lake Nature Center, 8477 East Mud Lake Road, Baldwinsville, NY. Directions on p.28.*



## CLUB WORKSHOP SATURDAY, FEBRUARY 18<sup>TH</sup> 9AM-NOON

The next club workshop will be held on the Saturday, February 18<sup>th</sup> which is the Saturday after the February turning demo. The workshop is held in the large garage at Charlie & Barbara's home a location affectionately known as the Eight Acres Event Center. One area of the garage is heated by a wood stove. This area contains 10 lathes and a scrollsaw, all owned by the club. During the colder months, the workshops are generally restricted to turning instruction. However, if a member wishes instruction on other topics, they can request it and if it cannot be accommodated on the normal workshop day, Charlie will work with them to schedule another time.

During the workshop, you can purchase sandpaper, Anchor Seal, or other consumables that the club purchases in bulk to help the members. You can also purchase wood from Charlie's huge stash. These items can be purchased at ANY time. You do not have to wait for a workshop day. Contact Charlie at any time either at [8acreswood@gmail.com](mailto:8acreswood@gmail.com) or 315-720-7151 to arrange a time to purchase whatever you need.

**Where?** The exact address for the club workshop is sent to all members by email before the event. It is located near the Northwest YMCA east of Baldwinsville. **NOTE:** We ask that you register by 5pm on February 17<sup>th</sup> so we know you are planning attend and what you plan to do during the workshop —email [woodcny@gmail.com](mailto:woodcny@gmail.com).

## DEMONSTRATION LOCATION & INFORMATION

The Woodworkers, & Turners demonstrations are held In-Person in the **Community Room at the Belgium Cold Springs Fire Dept Station One, 7920 River Road, Baldwinsville.** *Directions on page 28.*

When possible, we will also broadcast the demo via **Zoom** and distribute the link to members 1-2 days ahead. Our Zoom sessions open by 6pm

**Show & Tell:** Items accepted in-person. If you can't make it, send photos and descriptions of your projects to [woodcny@gmail.com](mailto:woodcny@gmail.com) by 3pm on the day of the demonstration so they can be incorporated into the slideshow.



## MIKE'S CORNER LET'S MAKE AN ICE CREAM SCOOP!

Mike Vecellio shares a variety of techniques he's learned with other members whenever possible. Here he talks about making an ice cream scoop. *Your articles are welcome anytime.* Please send to [woodcny@gmail.com](mailto:woodcny@gmail.com).

The other day when I was at a play date with Charlie, he informed me that our club now carries Ikea ice cream scoops for sale to our members.

I have been making these for a while, and now that the scoops are readily available, I thought that I would share my method.

Not only are these scoops good for ice cream, they also work great for cookie dough and meatballs.

The scoop comes with a nice stainless steel scoop and a cheap plastic handle. The first thing to do is to remove the handle.

The easiest method that I have found is to use a heat gun. Put on a pair of gloves and heat the scoop where the metal meets the handle down to about an inch. After about a minute you will be able to pull the metal scoop out of the plastic handle. *Figure 1* shows 2 scoops; one with the handle removed.



Next you will want to choose a blank. The blank should be about 1 1/2 inches square and 6 inches long. It can be a simple blank but I have found that mixed woods and hybrid blanks are very popular.

Mount the blank in a chuck with a live cone center in the tail stock



to be sure the blank is aligned properly. That is most important with mixed woods and hybrids. See *Figure 2*.



Once it is mounted drill a 21/64 hole 1 1/4 inch into the blank. See *Figure 3*.

Then put the cone center back in the tail stock. At this point use your imagination and turn the handle to the shape of your choice and finish it. I prefer wipe-on poly for the finish to protect the wood from water.

When the handle is finished, it is time to add the metal scoop. The metal scoop has two ears, one on each side. If the wood is soft enough you will be able to press it in without issue. If the wood is hard you may have to file a trench where the ears are going to be located. I like to dry fit the scoop before gluing. Once you are happy with the fit, put some epoxy glue in the handle and press the parts together. I like to put a clamp on the scoop for a few minutes while the glue dries. *Figure 4* shows 3 of my completed scoops.

I had a lot more, but they made great Christmas gifts. I would love to see a Show & Tell at a meeting where ice cream scoops take center stage. Why not pickup a few scoops at \$5 each and make some yourself!

*The club purchased 2 dozen Ikea ice cream scoops to be used by members to make scoops with hopes some will be then donated for our craft sales. They are available for \$5 each at workshops or by appointment.*



## UPCOMING TRAINING-WOOD BURNING



Location Change

There are many tools that members can use to embellish their projects. One of those is wood burning or commonly known as pyrography. Learning to use a wood burner is one of the skills members have requested during the past years. As a result the Board arranged for focused training on wood burning for 2023. Registration opened on January 15<sup>th</sup> and the rush was on. **As this newsletter is published there is 1 slot open for the workshop and 10 for the demonstration.** We will maintain a wait list but there is no guarantee. We are also working to provide an advanced class in 2023 or 2024.

### APRIL 2023 TRAINING:

**Sandra Sabene** of the Liverpool Arts Center will provide a 2 hour demonstration on Friday evening and then hold a beginners/intermediate 4 hour workshop on Saturday.

**DEMONSTRATION:** Friday Evening, **April 21, 2023** 6:30-8:30pm  
Held at Liverpool Art Center, 305 Vine St, Liverpool, NY  
Maximum 30 Attendees  
Cost: \$20 per person

**WORKSHOP:** Saturday Afternoon, **April 22, 2023** 1-5pm  
Held at Liverpool Art Center, 305 Vine St, Liverpool, NY  
Maximum 20 Attendees  
Cost is \$45 per person

**MATERIAL NEEDED FOR WORKSHOP:** Look for information in the next few months

**REGISTRATION:** Register and pay with PayPal via the website [HERE](#).

## WOOD BURNING INFORMATION

As promised, we are providing information for members about wood burning equipment and resources. Remember, decisions about what you purchase are your own. The club provides this information to help guide you in your decision-making process. We suggest that you always read and understand all instruction manuals and seek out experts to teach proper use of your tools.

## Wood Burning Equipment

Learning to wood burn is challenging and exciting. Woodburning can be a stand-alone art form or add embellishments and highlights to wood turned pieces, scrolled work, carved projects, or any woodworking project. The term pyrography includes woodburning and includes burning on other materials such as leather, paper, gourds, and metals. We are only addressing equipment that is suitable for woodburning, although it can often be used on other materials.

Finding affordable equipment can be challenging until you understand the different types of equipment and why the price varies from \$20 to hundreds of dollars to get started. There are two types of starting woodburning equipment: craft or hobby kits and professional kits.

Continued on Page 7

*The Basic Material Presented Here was Assembled on Behalf of Our Members by Chad Dawson*

*Have You Checked Out the Resources for Wood Burning on the Club Website?*

Link to it [HERE](#)

## WOOD BURNING INFORMATION—PAGE 2

### Wood Burning Equipment, *continued*

Craft kits tend to be made up as a single wand or pen, with a screw-in-tip system, that is plugged directly into the wall with an electric cord. Power is often not variable on the craft kits and the wand uses about 30 watts of power. Craft or hobby kits tend to include a set of solid brass tips that screw into the wand end. A few craft kits include wire tip burners that snap in the wand tip instead of screw in. Craft kits are simple, reliable, easy to use, and can be used with a wide variety of brass tip shapes. Craft kits run from \$20 to \$100 and can be purchased from many vendors, such as Amazon, Harbor Freight, Lowe's, Home Depot, Rockler, Woodcraft, Hobby Lobby, Michaels, and other woodworking and hobby stores.

Professional kits use wands or pens that are attached to a separate power box and the power box plugs into the wall. The pro kits offer more power and more control over the amount of heat in the tip and use 30 to 130 watts of power. Pro kits come with wire tips that slide or snap into a wand and some are secured with screws. The wire tips come in a wide variety of shapes and sizes and offer more precision than the solid brass tips found in craft kits. Individual pens with set tips can also be purchased for use with certain pro kits. Pro kits run from \$100 to over \$300 and can be purchased from many vendors, such as Amazon and the vendors listed on the club's website on the [Wood Burning Resources](#) page [HERE](#), some of whom have donated to the club.

### Considerations Before Buying Woodburning Equipment

**B**efore you buy your woodburning equipment, here are a few essential ideas you may want to consider:

- ◆ **Frequency & Amount of Use** — Will you use the equipment for adding a few small embellishments or highlights on your wood projects (*craft kit*) or do you plan to do extensive woodburning designs as a major and frequent art project (*pro kit*)?
- ◆ **Wood to be Burned** — Will you use the equipment on softer and less dense woods (*craft kit*) or harder woods and dense tropical woods (*pro kit*)?
- ◆ **Temperature Regulation** — Will you need a temperature regulator on your device (*pro kit*) because of burning on different types of wood and need more power to keep the tip a constant temperature with rapid temperature recovery as you burn? A craft kit is usually only one temperature (power) setting and may not recover to an ideal temperature quickly after some use.
- ◆ **Number & Types of Tips** — Will you need many different tips for the designs you want to achieve? While most kits come with a set of tips, is it easy to purchase additional tips for that tool? If you are involved in a detailed design project, you may find that a pro kit offers tips that can create finer details.





## WOOD BURNING INFORMATION—PAGE 3

### Wood Burning Equipment, *continued*

#### Safety

- ◆ **Fan & Mask** – Wood burning creates smoke. Wearing a mask when burning is suggested. Having a fan or some sort of fume extractor is also advised
- ◆ **Tool Handle** – The handle on your woodburning wand or pen needs to be heat-resistant, ergonomically designed, and easy to grip. You may need to use protective gloves when using the handle, especially at very high temperatures, so as not to burn your hands.
- ◆ **Stands** – You need to be mindful of where and how you place your wand (pen) to cool or heat up. Consider the nature of the stand you use to safely hold your wand (pen) when it is not in your hand.
- ◆ **Keep Away from Children** – Things like small interchangeable tips and extension cords can lead to health hazards, if left unattended. Hot tools are a safety hazard to children so select a workspace that is not close to young children and pets.
- ◆ **Unplug When Not in Use** – Small tools such as these should always be unplugged when you are not using them. If you connect to a power strip, turn the power strip off as you finish.
- ◆ These are only a few of the safety precautions for wood burning. Burn Savy has some other great thoughts. Check it out [HERE](#).

#### What to Purchase?

**W**ood burning kits and additional tips and tools are not expensive to get started. Woodburning tools are versatile in adding embellishments, highlights, art designs, hobby crafting, and even making letters for signs. If you are not sure which kit to purchase, consider starting with a craft or hobby kit with fewer tips. You can upgrade your kit as you improve your skills.

#### Wood Burning Resources

**G**etting started with woodburning is best in a class or workshop to quickly bring you up to a safe level of activity with a few techniques. Expanding your use of additional techniques beyond that beginning level and finding new patterns to try will require reading books, watching videos, searching websites, and attending more advanced workshops or classes. *And much practice!*

#### Books

**T**here are some excellent woodburning and pyrography books published showing different techniques, step-by-step instructions, photos and illustrations, and examples of appropriate patterns for projects at different levels of skill and interest. Books run from \$5 to \$50 and can be purchased online from your favorite book sellers or book stores. Also check what your local library has or can get on loan. Some of the woodworking websites also sell books that may not be available at common resellers. Search titles using the key words of *woodburning* and *pyrography*. Some books are available as e-books or as pdf files that are downloadable books through reputable publishing vendors. When searching the internet for free pdf books that are

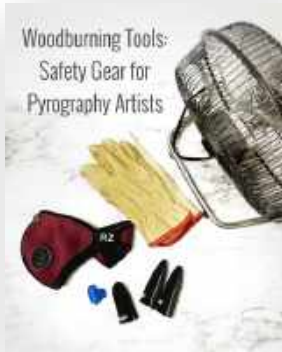



## WOOD BURNING INFORMATION—PAGE 3

### Wood Burning Resources, *continued*

offered through random websites, you may want to be cautious and have your virus software updated.

The top writers are Lora S. Irish, Michele Parsons, Simon Easton, and Sue Walters. There are others, just search, read the descriptions, and decide if it is something you want/need!

### Magazines

Many woodworking and hobby magazines include articles on woodburning. For example, if you are a member of the AAW, you can search their resources, including *American Woodturner* journal ([woodturner.org](http://woodturner.org)) on woodburning and pyrography to find a few articles and videos. Fox Chapel Publishing releases a special issue magazine, *Pyrography*, completely devoted to woodburning.

### Websites and Blogs

Author and teacher Lora Irish maintains a website ([LSIrish.com](http://LSIrish.com)) with many free resources and with over 550 pages of free tutorials, projects, and patterns for wood burning, pyrography, wood carving, relief carving, and other hobbies. There are free resources, patterns, a monthly newsletter, and a blog available if you join Wood Burn Corner's free [Burn Club](#). Aney Carver runs a website [Pyrocrafter](#)s that offers free tutorials, patterns, resources, and a blog. Fox Chapel Publishing maintains a free [Pyrography forum](#) that can connect you to many resources, get questions answered by other members, and join a community of other artists with similar interests. Moss Tangle Arts offers some free tutorials, patterns, and posts about woodburning on their [website](#). Burn Savvy also maintains a [website](#) with many free resources and advice on woodburning.

### Videos

The websites listed above have many free tutorial videos to get started and learn new techniques. More in-depth videos on techniques can be purchased through the various vendors listed above for books. The greatest number of free videos are available on YouTube. Search using keywords such as *woodburning*, *wood burning*, and *pyrography*. You will find numerous videos included in these searches about burning wood in fireplaces and stoves for heat, so the best word to use is *pyrography*.

**WARNING:** You will also find included in these searches some references to *fractal wood burning*. This is a **VERY** dangerous technique that can and has led to serious injury and death due to its use of high voltage electricity to cause the burning effects. The Woodworkers of Central New York does not endorse the use of this technique due to its inherent hazards.



One of Many Books Available

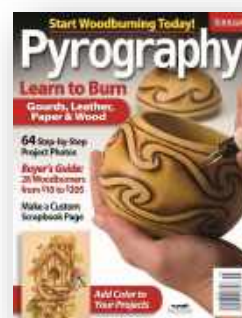

One of the Special Issues from Fox Chapel Publishing



Thank You Chad for  
Producing this  
Informational Article  
Want a Topic Featured  
in the Newsletter?  
Send a note to  
[woodcny@gmail.com](mailto:woodcny@gmail.com) with  
the topic or maybe  
assemble the material  
yourself and send.

## WOOD EDUCATION—EXPLAIN POPLAR?

Sometimes you select wood and one person says it is *poplar* while the other says it is *cottonwood*. Let's explore the difference!

The most common trees in the genus *Populus* include one true poplar in the north, four primary species of cottonwoods, and the quaking aspen. Most of the known 35 poplar species live in the Northern Hemisphere.

The cottonwoods thrive in wetland areas in eastern and western North America. The aspens are most comfortable in high-latitude environments dominated by conifers with aspen being a major broad-leaved species.

These are tall trees with sweeping branches, but are not very dissimilar which can be confusing. While their weak wood makes them a somewhat dangerous tree near buildings and dwellings, they have commercial value for the lumber industry.

### SIMILARITIES

Poplars, cottonwoods and aspens all are quite tall. They all have triangular leaves with long stems and silvery backsides, so leaves shimmer in the wind.

All have long reproductive catkins (*a cluster of single-sex flowers*) that appear just before the new leaves of spring. The resulting fruit is a capsule that opens into two to four parts. The tufted seeds are shed in masses of white *cotton* which can cover the ground inches deep. The wind carries these seeds between male and female catkins in order to reproduce.

### DIFFERENCES

Cottonwoods have more triangular or heart-shaped leaves than poplars, and the edges are slightly serrated. Poplar leaves have a more oval to oval-lance-like leaves. While all cottonwoods produce the cotton from which their namesake comes, some poplars do not, including the black poplar. Cottonwoods are also taller, ranging between 80 and 200 feet,

whereas the balsam poplar is only 80 feet and the black poplar a mere 40 to 50.

### CHARACTERISTICS OF POPLAR WOOD

- ◇ They are all relatively lightweight and soft (*as a matter of fact, the Populus species ranks among the very softest woods in the world*).
- ◇ They all have relatively small pores which finish to a smooth texture without the need for pore fillers.
- ◇ Most of these trees grow quite large and furnish wide, clear boards.
- ◇ Anatomically, they are all diffuse (or semi-diffuse) porous hardwoods.

### FUN FACTS

- ⇒ The Eastern Cottonwood is one of the largest North American hardwood trees.
- ⇒ The aspen has the widest range in the United States. It occurs throughout eastern United States and throughout Canada.
- ⇒ All poplars tend to be fast-growing species that are often use in ornamental gardens and residential landscaping. They can reach full height in 12 years.
- ⇒ They have wide canopies that make them great for providing shade. Some are suitable for natural privacy screens and for serving as a windbreak.
- ⇒ Yellow poplar or tulip poplar is not a true poplar.



## BEADS OF COURAGE BOXES

**B**eads of Courage is a non-profit organization that is dedicated to improving the quality of life for children and teens coping with serious illness, their families, and the clinicians who care for them. Children being treated for life-threatening illnesses are given beads as they undergo a variety of treatments. Boxes are one of the vessels in which they keep their beads.

The Syracuse Joslin Diabetes Center contacted the club requesting that our members make boxes for distribution to kids undergoing treatment for diabetes at the Center. They are looking for boxes of any type whether turned, scrolled, carved, or assembled using traditional woodworking. Members are encouraged to build and donate one or more boxes to fill the Center's urgent needs. Doug North, our president is managing our involvement in the program. Bring the completed boxes to meetings/other events or arrange for their receipt by Doug ([dnorth@twcny.rr.com](mailto:dnorth@twcny.rr.com) or 315-753-1121). We want to track and photograph each donated box.

**T**here are some guidelines for size, finish, etc. We recently clarified the sizes so these are revised guidelines.

### Wood Thickness & Weight:

- ◆ The boxes should not be heavy or bulky. Wall thicknesses should be ¼" to **not more than** ½". Please, not super thin and delicate.

### Dimensions:

- ◆ Turned Boxes: Around 6x6" - Not smaller than 5x5" and not larger than 8x8"
- ◆ Flatwork Boxes: Not smaller than 6x6x3" and not larger than 8x8x3"

### Base & Lids:

- ◆ Box bases should be wide enough so the box is stable & does not tip over easily
- ◆ Lids should be easy for small or ill children to remove or lift.
- ◆ Any finials should be easy for a small child to grasp and not too elaborate so they don't break

### Design Consideration:

- ◆ The boxes should be able to transition with the child into adulthood and be a keepsake for many years as the patients life with the diagnosis for a lifetime.
- ◆ Avoid excessively elaborate designs that may easily break or be damaged.
- ◆ If possible, incorporate one of the *Beads of Courage* beads into the box. See Barbara at any meeting to obtain one. The club purchased the beads

### Finishes:

- ◆ Please use a safe, non-toxic finish.
- ◆ Do not use finishes like linseed oil that take a long time to outgas.
- ◆ Refrain from painting the boxes. Instead, highlight the beauty of the wood with clear varnish, a stain, and/or wood burning.



### NOTE

The club secured 20 of the special *Beads of Courage* beads that can be placed somewhere on the inside of your box. Need one?

Request via email at [woodcny@gmail.com](mailto:woodcny@gmail.com) or ask at meetings or workshops.

## GIRL SCOUT WOODWORKING BADGE

**T**he Girl Scouts are looking for help from the club to complete their woodworking badge. There are specific steps they must complete to receive the badge. Can you help? Please let Barbara know by speaking to her at a meeting/event or by emailing [woodcny@gmail.com](mailto:woodcny@gmail.com). The initial idea is to build bluebird houses. The steps they need to complete are listed online [HERE](#) and itemized below:

1. Swing a Hammer
2. Keep it Level
3. Use a Screwdriver
4. Saw Some Wood
5. Build Something Yourself

Please consider helping. February is busy but maybe in March!







## SHOP TIME!

Shop Time is our column that brings you techniques that you can use in the shop. If you have some tips to share, please send to [woodcny@gmail.com](mailto:woodcny@gmail.com).

### Sled for Cutting Odd Shaped Wood

Over time, we've heard members say they want to cut "cookies" from a log or they are faced with cutting an odd shaped piece of wood. This sled offers a safer way to hold the log for cutting on your bandsaw.

Build yourself this bandsaw sled which uses four movable, curved jaws that pivot and slide on the base to almost any position. Create a plywood base and install a pair of T-tracks in grooves. Attach a hardwood runner that fits your miter slot and positions the base against the blade. Cut the jaws from 2-by stock the shape right as a guide AFTER sizing it upwards. Then, drill a hole in the "tail" of each jaw for a 1/4"-20 bolt. Prevent workpieces from slipping by adhering 100-grit sandpaper to the jaw faces. Add a bolt, jaw, washer, and knob to the T-track in the sled base.

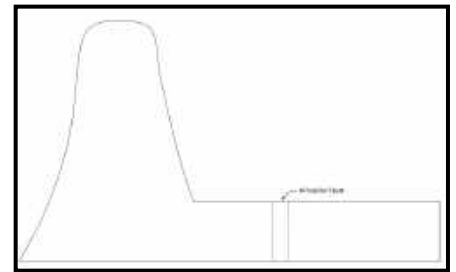
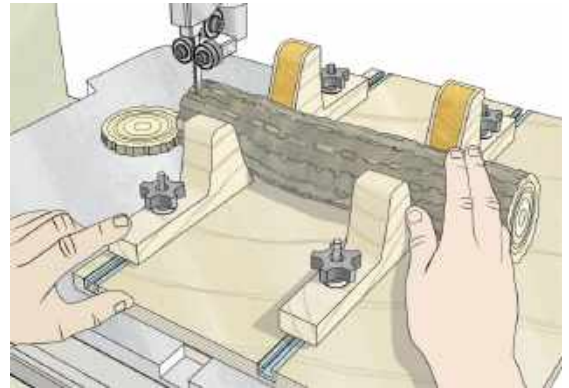

### Glue Top Popper

Sometimes the simplest action can derail us. Getting a glue bottle open is one of those actions. This simple bottle opener can end struggles with opening stuck glue bottles. It provides plenty of leverage to open a stubborn glue cap.

The opener fits over the bottle cap. A lip on the inside slips under the neck of the cap. It's made from a 3/4 x 1 x 4" scrap of hardwood. Use a Forstner bit to drill two 3/4" holes to fit over the largest diameter of the cap. The first hole is a through-hole. The second hole stops to leave 1/4" of material. Using the center point of the stopped hole as a reference, drill a 5/8" through-hole to fit around the neck of the bottle cap. A little cleanup with some files and sandpaper creates one of the handiest tools in your shop.

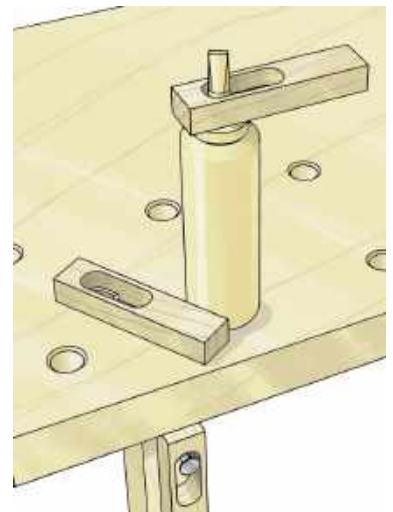

## MORE SHOP TIME!

### Simple Bowl Depth Guide

It's pretty simple but can save you from those embarrassing bottom of the bowl holes! Make it and use it!

This handy bowl gauge is used to identify how far you have gone in a bowl or vase. Cut a piece of wood as long as you plan on turning a bowl diameter plus a couple of inches. So for a gauge for ten inch maximum bowls, use at least a twelve inch long piece of wood. Drill a 7/32" hole at center, rotate the wood 90 degrees and drill a 1/4" hole. Use a 1/4" x 20 tap to thread the 7/32" hole. Insert a piece of 1/4" dowel through the unthreaded hole and a 1/4" bolt or thumbscrew through the threaded hole. The dowel is set to desired depth and the wood piece serves as a stop at the bowl's edges.

**Related Tip:** Replace the dowel with an antenna from a portable radio when doing long vases. It is light and easily retractable for storage. If you can not find an antenna, a magnetic pickup tool from a dollar store works also.



### Penny Pinching Glue Spreader

Got a plastic knife? Then you have a perfect glue spreader for projects!

The serrated edge creates a uniform thickness of glue, similar to a notched trowel for applying thinset tile adhesive. To control the thickness of the glue layer, simply tilt the knife. As an added bonus, dried glue easily flakes off the knife so you can reuse it often.



### Half Pencil Marks Exact Copies



An ordinary pencil becomes an excellent tool for tracing an accurate woodworking tool when it becomes a half-pencil through careful grinding on your belt sander. The flat edge rides straight along the edge of a template or other item needing accurate marking.



## MEMBERSHIP

**M**embership in the Woodworkers of Central New York (WWCNY) runs from January 1 to December 31. We opened up renewals as of October 1<sup>st</sup>. And, anyone who joins from October 1<sup>st</sup> forward also receives their membership for the upcoming year. We receive members throughout the year but do no prorate memberships based on when you join.

The Board continues to keep the membership price reasonable at just \$25 for individuals and \$35 for families with Junior free (with an adult membership). So far, we have 172 members for 2023, 53 of which are new as of October 1<sup>st</sup>. Welcome to all our new members. Please consider processing your renewal sooner than later. The benefits of your membership include:

- ◆ Access to all demonstrations/meetings/workshops/other events
- ◆ Monthly 30 page newsletter
- ◆ Access to Member-Only section of robust website

### States with Members:

We have members in the following states: New York (of course), Massachusetts, Connecticut, Pennsylvania, Virginia, North Carolina, Georgia, Illinois, Ohio, and Tennessee!

### Member-Only Area Password

The *Member-Only* area of the website contains a variety of Corporate documents as well as the current 4 months of newsletters and links to all videos produced by the club. The password for this area is changed on April 1<sup>st</sup> of each year so only members have access to the data. We do not publish the password anywhere. You must request it by sending an email to [woodcny@gmail.com](mailto:woodcny@gmail.com). You can also ask about it at any meeting.

## MEMBERSHIP BADGES

**D**o you have a membership badge? We encourage all members to wear one at all demonstrations, workshops, or other events! Don't assume *everyone knows* who you are!

Don't have one? Want to buy one? We have a new form available at demos. Plus, there is a new page on the website to just order badges. Under *Home*, select **Order a Badge**.

They are \$9. Each badge includes two options for attaching to your clothing – a magnet or a pin. Please pick up at a meeting or other event. If you want it shipped it will cost an additional \$2.

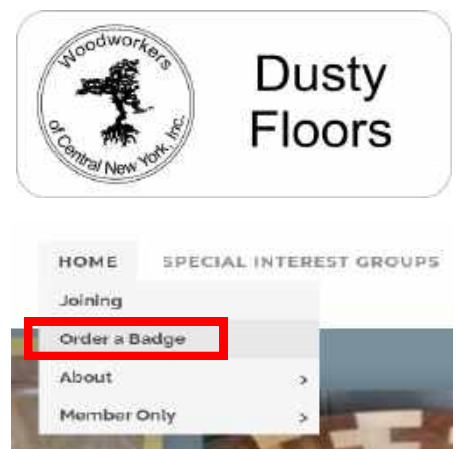



## SHOW & TELL JANUARY 2023

After a light December for *Show & Tell*, we have a bundle for January, enough that I am adding pages as necessary to the newsletter. As usual, you can always send photos and descriptions of your recent projects to woodcny@gmail.com any time during the month.



**Tom Lawlor**  
Cherry Folding Stool  
Shellac & Waterlox



**Chad Dawson**  
Post & Rung Ash Stool  
Poly Finish & Woven  
Danish Paper Cord Seat



**Terry Dote**  
Multi-Wood Jewelry Box  
with Inside Trays  
Shellac



**Don Vanderveer**  
Capello & Hard  
Maple  
Charcuterie  
Board  
Walnut Oil

**Simeon Warner**  
Spalted Maple Cup  
Thin Maple Green  
Bowl w/Linseed Oil &  
Beeswax  
Walnut Bowl w/  
Linseed Oil &  
Beeswax



**Rod Castle**  
Laminated Crush Grind Pepper Mill;  
Spalted Maple Awl; Laminated Coffee  
Scoop; Acrylic Letter Opener; Burl &  
Ebony Center Teachers Pen



**Mark Anastas**  
Ambrosia Maple Bowl



**Ed Siegel**  
Ash Salad Bowl w/Mineral Wax & Beeswax  
Spalted Maple Platter w/Wipe-On Poly & Buffed

# SHOW & TELL JANUARY 2023, PAGE 2



**Davenport Desk**  
Found at a Sale  
Unknown Wood or Finish



**Charlie LaPrease**  
Ash Bowls  
No Finish—Tooling  
Only



**Quarto** is a board game for 2 players invented by Swiss mathematician Blaise Muller. It is considered an impartial game because there is only one set of common pieces.

**Robert Love**  
Quarto Game Board & Turned Pieces

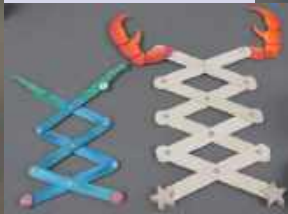

**Jim Yonkers**  
Venus of Willendorf Replica Carving  
Toys from Craft Sticks  
Cedar Lidded Box (Donated for *Beads of Courage*)



**Paul Depew**  
Black Walnut Bowl w/  
Tried & True  
Black Locust Bowl with  
Danish Oil

**Venus of Willendorf**  
Created maybe 25,000-30,000 years ago and found in 1908, it is suggested that she is a fertility figure, a good-luck totem, a mother goddess symbol, or an aphrodisiac made by med for the appreciation of men. Original carved from oolitic limestone. Houses in the Natural History Museum in Vienna, Austria.

# SHOW & TELL JANUARY 2023, PAGE 3



**Ted Kleege**  
Snowmen (2 Donated)  
Pine/Cherry & Maple/Walnut



**Dave Grant**  
Bowl (L)—Pallet Wood w/Tung Oil Finish  
Bowl (R)—FOG Wood w/Red Dye & Spray Lacquer  
Snowman—FOG Wood, Friction Polish & Acrylics  
[Turn the Hat & Lights Come On! Used Cork Wine Bottle Lights]  
Trees of Various Woods & Finishes



**Jim & Shelli Kent**  
Flaming Red Box Elder Stool w/  
Danish Cord Woven Seat  
Cherry w/Walnut Inlay Finial Box



**Bill Shea**  
Walnut Secretary Desk  
Shellac and Behlens Wipe-on Varnish



**Scott Harrison**  
Bandsaw Deer  
for Xmas Gifts

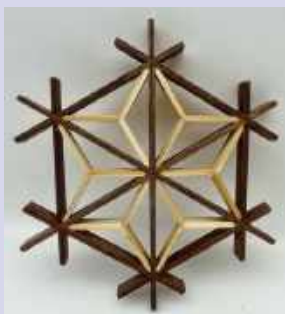

**Tom Cooney**  
Walnut & Pine Asa-No-Ha Pattern Kumiko  
Curly Maple Birdhouse Ornament  
Pine & Walnut Open Ornament with Bell



# SHOW & TELL JANUARY 2023, PAGE 4



**Martin Meiss**  
Split Log Ash Bench (T-L); Sugar Maple Notched In Bench (T-C); Walnut Crotch Side Table (T-R); Honey Locust Milking Stool (B-L); Spalted Maple, Gas Pipe & Rebar Book Rack (B-C); Old Barn Timber, Angle Iron & Threaded Rod Coffee Table (B-C); Spalted Maple Egg (B-R)



**Westbrook Shortall**  
Black Walnut Pedestal  
Norfolk Island Pine Bowl



Molly

**Molly Helping Make Badges**  
Bruce & Marion Meissner's Dog Molly Loves to Sleep on Bruce's Table Saw When Not in Use! Here, She is Helping Him Make Badges!



**Larry McConnelee**  
A Variety of Projects Made for the Grandkids as Christmas Gifts



# SHOW & TELL JANUARY 2023, PAGE 5



**Arlie Howell**  
Red Tailed Hawk & American Kestrel



**Gregg Shinneman**  
Monarch Butterflies  
Boot



**Harold Kaltenbach**  
Whimsical  
Cottonwood Bark  
Houses  
Mushroom House



**Dave Weir**  
Santas & Xmas Ornaments



**Mike Bloomquist**  
3 Simple Santas, Cross Country Santa, Harvey Reasal Tomte, Dragon,  
"Shroom Skirit", and Skull & Candle



**Arlene Schlueter**  
Deer in Woods  
Slab Wood  
Woodburned @  
Cherry Ridge NEWR



# SHOW & TELL JANUARY 2023, PAGE 6



**Jim Yonkers**



**Gary Morison**  
January &  
February Carving  
Project by Gary



**Gary Morison**  
Variety of Basswood Carvings



**Barbara Raymond-LaPrease**  
Christmas Gifts – Cherry Fire Truck Customized with Wood Burning; EMT Plaque with Blue Acrylic Backer; Grandparents Plaque with Spot for Photo; Cardinal Plaque with Acrylic Backer; Ornaments; Special Gift for 53 Years of Fire Service





# CLUB EXHIBIT IN BALDWINSVILLE LIBRARY



On January 2<sup>nd</sup>, we were notified that the club was scheduled to place an exhibit of member's projects in the Baldwinsville Library for January. Quickly, an email was distributed and our members stepped up with an impressive group of 90 projects for the display. If you didn't have a chance to visit the exhibit in person, here are photos of the exhibit over 2 pages.



*The Central Covered Case*



*The Wall Area*



**Touchable Toys Area**  
*A Was Big Hit with Kids & Adults*



*Continued on Page 22*

# CLUB EXHIBIT, PAGE 2





## JANUARY 2023 WORKSHOP

The January 2023 club workshop was very popular. Many of our new members attended and worked with one of the five mentors. Here are the photos from that event.



## WOODWORKERS OF CENTRAL NEW YORK

### Woodworkers of Central New York, Inc. Leadership

[Doug North](#), President  
(315) 753-1121

[Larry Prunotto](#), Vice President  
(315) 652-3605

[Barbara Raymond-LaPrease](#),  
Secretary (315) 345-5381

[Brad Rees](#), Treasurer  
(315) 391-2723

### Special Interest Groups Chairs

[Gary Morison](#), Carvers  
(315) 327-9157

[Robert Ward](#), Scrollers  
(315) 506-8305

[Mark Anastas](#), Turners  
(315) 863-4483

[Charlie LaPrease](#), Woodworkers  
(315) 720-7151

### At-Large Board Members

[Kerry Kopkey](#) (315) 593-6914

[Robert Love](#) (315) 297-4224

[Bruce Meissner](#) (315) 699-3671

[Rod Castle](#) (315) 638-2659

[Todd Reilly](#) (315) 263-3410

[Arlene Schlueter](#) (315) 720-6633

[Mel Taber](#) (315) 487-7855

[Paul Tennant](#) (315) 676-3469

### Board Committees

*Financial Oversight*  
Larry Prunotto (chair)

*Charitable Giving*  
Susan Allen (chair)

*Nominating*  
Chad Dawson (chair)

*Web & Social Media*  
Robert Love (chair)

*New York State Fair*  
Barbara Raymond-LaPrease (chair)

*Facebook*  
Todd Reilly

*Newsletter Editor*  
[Barbara Raymond-LaPrease](#)

Membership in the Woodworkers of Central New York, Inc. is open to anyone interested in all genres of woodworking. Membership covers all Special Interest Groups – Carvers, Scrollers, Turners, & Woodworkers. No additional fee is needed to participate in these Committees unless there is a workshop fee.



There are several types of members:

- ◆ Individual Membership: \$25
- ◆ Family Membership (all living at the same address): \$35
- ◆ Junior Membership (Ages 8-17): Free with adult membership
- ◆ One Day Membership: \$5
- ◆ Honorary Membership: Board Selection

Membership applications are available on the website [www.woodcny.org](http://www.woodcny.org).

Badges are an additional \$9 per person with a \$2 charge to mail the badge.

The Corporation leadership, with contact information, is listed right as a reference. Feel free to contact any club leader to ask questions, suggest programs, or deal with issues.

You should have an active email address if you are a member as the leadership sends many member communications via email as well as this newsletter. To read the newsletter you need to have a PDF reader product such as [Adobe Acrobat Reader](#) installed on your computer.

Adobe Reader is free. Due to its size, we prefer not to send newsletters by mail unless specifically requested.

The Woodworkers of CNY was formed in September 2017, to combine the three existing woodworking groups in Central New York into one consolidated entity. Four *Committees of the Corporation* (aka Special Interest Groups) focus member's attention on three specific genres—carving, scrolling, & turning—as well as the broader, all-encompassing general woodworking area. Members may attend any of the meetings at no additional charge (unless there is a project or speaker charge).

The Woodworkers of CNY was reaccepted as a chapter of the American Association of Woodturners (AAW) in May 2018. We encourage you to join AAW as it is an excellent organization with great resources as a member. Membership in AAW costs either \$50 for an online only or \$60 for a paper-based membership. Each membership includes the 6 issues of the journal, *American Woodturner*, with the online membership receiving it only online. You also have access to a large collection of online resources such as the publication *AAW Fundamentals* which is published on the off months from the journal.



AAW is an international organization of over 14,000 members of varying woodturning skills. In addition to receiving current issues of the journal, *American Woodturner*, membership also provides online access to all past issues of the Journal from 1986 forward. Access to a Resource Directory is also available only to members. Members of AAW also receive savings of up to 50% on AAW merchandise, including project books, DVDs, logo apparel, and more. Members can apply for an educational opportunity grant whereby an individual can receive compensation toward woodturning education for expenses such as tuition, registration, travel, lodging, meals, etc. They can also apply for professional outreach program fellowship grants to encourage creative growth or research, or to provide inspiration for new directions in turned wood art. The AAW Forum is also available to members as are other restricted articles and resources on the AAW website. Members receive a discount on registration for the annual Symposium which is in Louisville, Kentucky in 2023. Check out the AAW website - [www.woodturner.org](http://www.woodturner.org).

**Woodworkers of Central  
New York, Inc.**  
3405 Patchett Rd  
Baldwinsville, NY 13027



## NWA'S SHOWCASE & TOTALLY TURNING

On March 25<sup>th</sup> & 26<sup>th</sup>, the Northeastern Woodworker's Association (NWA) will again present their annual woodworking event—a combination of two (2) events — *Showcase* and *Totally Turning*. The event is held at the City Center in Saratoga Springs.

This is a club-run event working to rebuild since the pandemic. It includes free seminars as part of *Showcase* (\$16) and paid demonstrations if you register for *Totally Turning* (\$200 pre-registered). The groups share the vendor hall. And, each group presents their own displays of woodworking projects judged by woodworkers and awarded ribbons [*you can look at both!*].

For Showcase, there are 24 categories in pieces are entered (*multiple entries in each category allowed but only one piece is judged*). This year there is a special challenge category for coasters. There are 10 categories for *Totally Turning* and a special category for tops. **You do not have to be a member to enter projects, just deliver them by 6pm on Friday afternoon.**

**Demonstrators for Showcase Are:** Stanley Blanchard, Mike Bloomquist (*our member*), Garrett Hack, Andrew Hunter, Harold Kaltenbach (*our member*), Kuniaki Kishi, Eric Marczak, Scott Oliver, Dave Parkis, Paul Rund, Steve Schoenberg, and Juliana Shei

**Demonstrators for Totally Turning Are:** Cindy Drozda, Jim Echter, Beth Ireland, Mark Dreyer, Michael Kehs, Glenn Lucas, Hans Weissflog, Todd Gunter, Jason Nemec, and Chris Stolicky

More details about the events, demonstrators, demonstration topics, vendors, and entry categories are found on the websites for each event:

[Showcase](#)   [Totally Turning](#)

Many stay at the [Saratoga Hilton](#) but there is also a Hampton Inn nearby. Many members of the club attend this event and often gather together for meals at nearby restaurants.

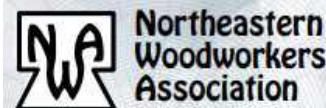

## UPDATES

- ⇒ **Maker Faire 2023 – April 1, 2023** – Lemoyne College Gym – More details later but the club expects to participate again. Plan on helping
- ⇒ **Videos on Website** – We are working to add the videos as soon as possible after the demonstration. At the January Board of Directors meeting, an additional safety message was discussed to be added to each video going forward. Check the website [HERE](#) regularly to see what is added. A note is added to the *What's New* area on the Home Page to let everyone know.
- ⇒ **2023 Shaker Box Classes** – Cancelled due to Bob Casey's death. More information on the return of these classes later in 2023.
- ⇒ **Challenges** – Both the Turning and Scrolling SIGs are running Challenges at meetings with prizes for winners. Plan to participate!
- ⇒ **Amazon Smile** – We were notified that Amazon is stopping this program as “they were not making as big an impact as they thought it would”. We will receive a final payment in 2023.
- ⇒ **Tool Raffles** – We are restarting tool raffles. The length of each raffle will be at least one month but could be more if the tool is of higher value. All members may participate by purchasing tickets at any event. New York State limits how we can run raffles.

**Maker Faire Syracuse**



**CHALLENGE YOURSELF**





We are ordered some of the Ikea ice cream scoops for members make wooden handled scoops for our sales. They are available in the workshop.

Remember We have small eye hooks available to purchase!  
100 in Brass or Silver for \$1.00

## Now Is THE TIME ... !

The club supports local children’s charities by donating money made from the sale of crafts donated by its members at 3-5 locations yearly. The sales are over for 2022. Our first event for 2023 looks to be the Crawfish Festival on Saturday, May 6 in Clinton Square. This event could be huge for us but we need to make sure we have enough product to sell. And, it would be really cool if we had some items that relate to the Crawfish Festival.

People ask what they can donate. Most anything is happily accepted. We received 4 music boxes before the Manlius Show and they were gone by noon on Saturday. Here are some of the typical items we are looking for in non-ornaments, scrolled, and turned. Carved? Always looking for items. Woodworkers ... Small boxes are one idea and I know there are others!

### Non-Ornament Items:

Small Cars/Trucks/Planes, etc.	Small Vases/Weed Pots	Candlestick/Tea Light Holders	Ice Cream Scoops	Small Cutting Boards
Small Puzzles	Pens	Rattles	Wizard Wands	Magnets
Small Boxes	Small Clocks	Seam Rippers	Letter Openers	Screw Drivers
Light Pulls	Keychains	Ring Holders	Magnets	Yo-Yos
Small Bowls	Various Kitchen Ware	Magnifiers	Kaleidoscopes	Snowmen

**Scrolled Ornaments:** Most any ornaments are welcome. We have plenty of smaller flat crosses. We need a variety of flat scrolled ornaments like:

Angels, Santas, Elves, Snowmen, & Other Holiday Related	Transportation Images like Trains, Planes, Cars	Service Groups like Firemen, Policemen, EMS, & All Military Branches
Birds like Hummingbirds, Cardinals, Eagles, Owls, Penguins, Chickadees, etc.	Fish, Bugs, Ladybugs, Butterflies, Flowers, Trees (Palm Tree), Other Flora, Whales, Shark, Octopus, etc.	Animals like Horses, Dogs, Cats, Elephants, Lions, Bears, Koala Bears, Hedgehogs, Dinosaurs, Dragons, Tigers
Sports esp. <i>non-standard</i> ones like Lacrosse, Snowboarding, Cycling, Wrestling, Volleyball, Ballet, Dance, Fencing, Sailing, Field Hockey, Crew, but also Baseball, Basketball, Football, Soccer, Field Hockey, Cycling, Hockey, Skiing, Running, Golf, Gymnastics, etc.		

### Turned Ornaments – Here are a few ideas:

Sea Urchins	Hollow Balls with Finials	Bird Houses
Angels	Light Bulbs of Multiple Sizes	Small Lighthouses
Drums, Bells	Trains	Snowmen of All Types & Shapes <i>Can Stand Alone or Hang as an Ornament</i>
Lollipops	Ice Cream Cones	Acorns, Mushrooms
Gnomes/Gonks	Trees—regular & windswept	Sleds with People On

**Holiday-Related Items** – We need multi-piece nativity scenes. We need larger crosses (6-12”) and have plenty of smaller ones. We need angels. We could use items depicting the 12 days of Christmas, esp. *Partridge in a Pear Tree*. We only have dreidels for patrons of the Jewish faith.

**Making Small Toys?** Consider leaving them unfinished and providing a cheap paint set or crayons for the kids to decorate their own!

## LOCATION OF MEETINGS

As some of you know, there is an issue between the Belgium Cold Springs Fire District Board of Fire Commissioners (BOFC) and Charlie and Barbara. The club meets for free at Belgium Station 1 because Charlie is a member of the Department. Newly issued restrictions on the use of the Community Room may impact our ability to meet at the firehouse. Straight answers are difficult to obtain from the BOFC. We secured the firehouse for February thanks to another fire department member who stepped up to use his 2 months so we can hold the both the Woodworking and Turning SIG meetings at the firehouse. As a newly elected Fire Commissioner, Charlie is working to resolve it but we don't know as we go to print how that will go.

We did not request use of the facility for Scrolling SIG meetings and Board meetings. The Scrolling SIG session will meet in February at Eight Acres and via Zoom. Board meetings are currently via Zoom. The Carving SIG continues to meet at Beaver Lake Nature Center.

The Board of Directors is appealing to our membership to identify other locations where we could meet in the future. Obviously, we would prefer to stay at the firehouse but the current climate there is not very welcoming despite the club's past donations and both Charlie and Barbara's ongoing contributions to the department. If you have ideas, please send to [woodcny@gmail.com](mailto:woodcny@gmail.com). In the meantime, be very aware of meeting locations identified in the newsletter and on the website. The website is the most current. If you have questions, please ask.



## SENDING PHOTOS

We love photos of your projects! We use them for this newsletter, for the online *Show & Tell*, for our website, and for our club slide show.

### *HOW DO YOU SEND PHOTOS? HERE ARE THREE (3) WAYS:*

Send the Photo by **Email** to the club email: [woodcny@gmail.com](mailto:woodcny@gmail.com). Add any additional information in the email that tells others about your project.

**Text the Photo** to Barbara's cell (315-345-5381) along with information. Remember, be sure to identify yourself!

**Got Lots of Photos?** Use a free product called **WeTransfer** [here](#) to send multiple photos. You can also use the *WeTransfer* app from your phone.

### *WHAT ELSE SHOULD I SEND WITH PHOTOS?*

With your photos, please send information about the projects shown in the photos – a brief description that should include wood used, finish, and any other information that makes it unique, even stories about the photos.



Preferred Method

## FINDING EQUIPMENT/SUPPLIES LOCALLY

**AJ SAFETY & SUPPLIES**, 1859 Lemoyne Ave, Syracuse (former Syracuse Industrial Sales Building). 315-478-5751 Website is [ajsafetyproducts.com](http://ajsafetyproducts.com)

**MCQUADE & BANNIGAN**, 6300 East Molloy Rd, East Syracuse. 315-671-4400 (their primary office is in Utica 315-724-7119 and they have an office in Watertown 315-788-2612 Website is [mqb.com](http://mqb.com))

**GRAINGER INDUSTRIAL SUPPLY**—Syracuse Branch, 6285 Molloy Rd, East Syracuse. 800-472-4643 Website is [grainger.com](http://grainger.com)

**RUMETCO SALES**, 610 Bear St West, Syracuse. 315-422-0237

**HIAWATHA FASTENERS**, 6312 East Taft Road, North Syracuse. 315-452-0033



## Need Sandpaper or Other Supplies?

Call Charlie to Schedule a Time to Visit Eight Acres to Purchase or Come on Workshop Days



## CORPORATION SUPPLIES, LOANS, & SALES

### CONSUMABLES FOR SALE:

- ◆ **Ikea Ice Cream Scoops** \$5 each
- ◆ **White Abrasive Pads** (1200-1600 grit) [for applying finishes like Osmo] \$2 each
- ◆ **4 x 1/4" Pan Head Screws**—perfect for use with sawtooth hangers—Bag of 20 for \$1.25
- ◆ **Sawtooth Hanger**—9/16"x5/16" or 7/8"x5/16"
  - ◆ Bag of 10 for \$0.50
- ◆ **Miniature Drill Bits**
  - ◆ 1/16" (#52), 3/64" (#56), & 1/32" (#68)
  - ◆ 10 per package—\$6.50 per package
- ◆ **Drill Chuck Adapter for Miniature Bits**
  - ◆ \$11 each
- ◆ **Screw Eyes**—bag of 100 is \$1
- ◆ **Carborundum Sandpaper Sheets**
  - ◆ 80, 100, 120, 180, 240, 320, 400, 600, 800, and 1000 grit
  - ◆ \$1 per sheet or 6 sheets for \$5
- ◆ **Carborundum Sanding Pads—\$2 per pad**
  - ◆ Grits – medium (120-180), fine (320-400), superfine (500-600), ultrafine (800-1000), & microfine (1200-1500)
- ◆ **Sanding Discs from Woodturners Wonders**—bags priced
  - ◆ **Purple in 1", 2" or 3"**
  - ◆ **Wonder Weave in 2" or 3"**
  - ◆ **Green Wave Oversized in 2"**
  - ◆ Packaged in bags or 5 of lower grits: 60, 80, 120, 180, 240, 320, 400, & 600 or higher: 800, 1200, 1500, 2000, & 3000
- ◆ **Sanding Pad Holder Kits & Rolac Kits**
  - ◆ 2" & 3" sizes—bags priced
- ◆ **Anchor Seal**
  - ◆ Seals end grain of green wood to encourage slower drying
  - ◆ \$10 per gallon jug

- ◆ Available at meetings if you call Charlie LaPrease (315-720-7151) one day ahead
- ◆ Also available at Eight Acres by apmt.

NOTE: All prices include sales tax which the Corporation pays on an annual basis to New York State.

### TOOL LOAN PROGRAM

The Corporation owns a variety of equipment that members can borrow of a **maximum of one (1) month** at a time. This program is a way for beginners—or even seasoned woodworkers—to experiment with tools before purchasing. Some tools are stored at the Eight Acres Workshop while others, like the carving tools, are not. If you have an interest in borrowing tools, please send an email to [woodcny@gmail.com](mailto:woodcny@gmail.com). Your request will be directed and answered as appropriate.

With recent donations by members, we are expanding our collection of traditional tools and will be making more of those available for loan or even use at Eight Acres during both workshops and times scheduled with Charlie. Need something? Please ask!

### BOOK LOAN PROGRAM

The club has a mini-library with these and other titles:

- ◆ *Hogbin on Woodturning* by Stephen Hogbin
- ◆ *Woodburning with Style* by Simon Easton
- ◆ *Learn to Turn* by Barry Gross
- ◆ *O'Donnell's Woodturning Techniques* by Michael O'Donnell
- ◆ *Pen Turner's Workbook* by Barry Gross
- ◆ *Woodturning Chessmen* by Mike Darlow
- ◆ *Woodturning Methods* by Mike Darlow
- ◆ *Woodworker's Guide to Turning* (Back to Basics)

Do you have books you want to donate? Bring them to Michelle at any Turners meeting.

## SHARPENING SERVICES

Where can you get table saw blades and other tools sharpened?

**Ken of All Around Sharpening Services** is located in Jordan but you can drop off your items for sharpening at the Baldwinsville Supply which is at 82 East Genesee St (aka Rt 31, just east of the railroad tracks). Ken's cell phone is (315) 689-3184. Email is [sharpeningguy@twcny.rr.com](mailto:sharpeningguy@twcny.rr.com).

**Paul E. Hart** runs a service at 118 Fish Road, Mexico, NY 13114. The phone number is (315) 936-1880. Drop box at new address but picks up blades, etc. at Wiley Lumber & Doow Lumber in East Syracuse as well as Tracy Lumber & Ace Hardware in Fayetteville.



## AMERICAN ASSOCIATION OF WOODTURNERS

### WHY SHOULD I JOIN?

You enjoy woodturning and want more. Your club, the Woodworkers of Central New York, is a chapter of the American Association of Woodturners – AAW. What does that mean for you as a member of our club?

AAW offers the club officers access to a variety of resources from the AAW to help manage the club, including a negotiated reduced price for our corporation's liability insurance. We pay nothing else to AAW to be a chapter.

So what's in it for you? There are many great tools available to you as a member of AAW. You can explore the AAW website to learn about all

the resources you receive with your membership. Two of the biggest is the bi-monthly journal, *American Woodturner*, and the online only product, four issues of *Woodturning FUNDamentals*.

#### What's the Cost? \$60 per year

That's the cost if you want to receive a physical journal. If not, pay \$50 per year.

For each family member (associate), you pay an additional \$5.

Students aged 10-25 pay just \$29 annually for their membership

Join Today [here!](#)



## IN-PERSON WOODWORKING CLASSES

We are listed a few of the "local" craft/woodworking schools that hold classes on a variety of topics. As usual, checking a organization's website and/or calling the is the best way to verify class availability.

#### Adirondack Folk School

Lake Luzerne, New York

[www.adirondackfolkschool.org](http://www.adirondackfolkschool.org)

#### Appalachian Center for Craft

Smithville, Tennessee

[www.tntech.edu/fine-arts/craftcenter](http://www.tntech.edu/fine-arts/craftcenter)

#### Arrowmont School of Arts & Crafts

Gatlinburg, Tennessee

[www.arrowmont.org](http://www.arrowmont.org)

#### Connecticut Valley School of Woodworking

Manchester, Connecticut

[schoolofwoodworking.com](http://schoolofwoodworking.com)

#### Florida School of Woodwork

Tampa, Florida

[schoolofwoodwork.com](http://schoolofwoodwork.com)

#### John C. Campbell Folk School

Brasstown, North Carolina

[folkschool.org](http://folkschool.org)

#### Marc Adams School of Woodworking

North Franklin, Indiana

[www.marcadams.com](http://www.marcadams.com)

#### Pocosin Arts School of Fine Craft

Columbia, North Carolina

[pocosinarts.org](http://pocosinarts.org)

#### Snow Farm / The NE Craft Program

Williamsburg, Massachusetts

[www.snowfarm.org](http://www.snowfarm.org)

#### The Woodright's School

Roy Underhill's school

Pittsboro, North Carolina

[www.woodwrightschool.com](http://www.woodwrightschool.com)

#### The Woodworking School at Pine Croft

Connected with Berea College; the former Kelly Mehler school

Berea, Kentucky

[pinecroftwoodschool.com](http://pinecroftwoodschool.com)

Do you know of other schools?

Please send the information to [woodcny@gmail.com](mailto:woodcny@gmail.com).

## CLASSES, EVENTS, & SYMPOSIUMS

### REGIONAL CLUB ACTIVITIES



#### Finger Lakes Woodturners

Meetings of the Finger Lakes Woodturners appear to be a combination of in-person and remote

demonstrations. They've scheduled several sessions with professional turners through September 2023. They generally hold their meetings on the 3<sup>rd</sup> Thursday of the month.

The February 16<sup>th</sup> event is **2-Legged Stool** demo with Larry Lobel. Planning ahead, their March 16<sup>th</sup> session is an IRD with Michael Gibson on **Two-Part Teapots**

Their website is: [here](#).

#### Rochester Woodworkers Society

The Rochester Woodworkers Society's *National* meetings are held in the Basil Hall at St. John Fisher's College. .

Their website shows no upcoming National Meetings.

Check their website for more information – [RWS website](#)



### OTHER EVENTS OF INTEREST

#### The Woodworking Shows

*Regional Show featuring a Variety of Equipment Vendors, Demos & Instruction, and Local Club Demonstrations*

February 3-5—Atlanta, GA

February 10-12—New Jersey

February 17-19—Milwaukee, WI

**2023 Annual Woodcarving Show: *Wonders in Wood* – Animal Woodcarving & Wildlife Art Festival** featuring Kevin Applegate  
March 11-12, Millersville University, Millersville, PA (near Lancaster)

Website: [here](#)

#### 2023 Northeast Woodworkers Association (NWA) Showcase & Totally Turning

March 25-26, City Center, Saratoga, NY

Website: [here](#)

#### 2023 American Association of Woodturners Symposium

June 1-4, Louisville, KY

Website: [here](#)

#### Northeast Woodcarvers Roundup 2023

July 16-20, Cherry Ridge Campsite, Honesdale, PA Website: [here](#)

#### Mystic Woocarvers *present* Woodcarvers Retreat of New England

September 15-18, Wisdom House, Litchfield, CT Website: [here](#)

#### Mid-Atlantic Woodturners Symposium

September 22-24, Marriott, Lancaster, PA

Website: [here](#)

#### Northeast Woodcarvers Fall Carve-In

September 22-24, Cherry Ridge Campsite, Honesdale, PA Website: [here](#)

## DIRECTIONS TO EVENT LOCATIONS

Always check the website to identify the location of events. It has the latest information. Club Workshops are held at the *Eight Acres Event Center*, a private home near the North Area YMCA, east of Baldwinsville, NY. The address is available by request: [woodcny@gmail.com](mailto:woodcny@gmail.com)

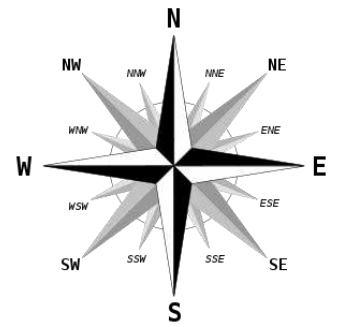

## CARVERS DEMONSTRATIONS/EVENTS

The Carvers meet in the large Community Room at the [Beaver Lake Nature Center, 8477 East Mud Lake Road, Baldwinsville, NY.](#)

The Nature Center is located west of the Village of Baldwinsville and west of Route 690 North. Mud Lake Road is about 1 3/4 miles west from the 690 exit ramp for Route 370. There is an animal hospital just past Mud Lake Road across the street. The entrance to the park is about 1/3 of a mile from your turn onto Mud Lake Road.

The entrance is on the left. Follow the roadway in, wait for the traffic arm to raise and park in either of the lots. Walk to the main building, enter, turn right, and then right again into the large room.

After meetings end, you will exit by the same roadway. If the traffic arm is down, buzz the desk and tell who answers you are with the carvers. They will lift the gate for you to drive through. There is no charge for parking.

## WOODWORKERS & TURNERS DEMONSTRATIONS/EVENTS

Demonstrations & events are held in the [Community Room at Station 1 of the Belgium Cold Springs Fire Department, 7920 River Road, Baldwinsville, NY.](#)

The fire station is located southeast of Baldwinsville just south of the intersection of three roads—River Road, Hicks Road, and Patchett Rd.—off River Rd.

If you take Rt 370 north from John Glenn Blvd, River Rd is the first right after going across the bridge. The firehouse is 2 miles from that turn. You can also go to the traffic light on Rt 370 which is Hicks Rd, and make a turn onto Hicks (head up the hill).

If you are coming from Rt. 31, take a left onto River Rd (on the west side of Belgium Bridge), and head south

about 2 miles past the new YMCA.

**Please be aware that when attending meetings or events at the firehouse, DO NOT park on the grass or in front of the firehouse bay doors. If there is an alarm, the firefighters will drive right over your vehicle if it is in the way. The septic system is in the grassy areas. There is plenty of street parking. The entrance is on the north side of the building.**

**Do Not Drive or Park on the Grass!**

## SCROLLERS DEMONSTRATIONS/EVENTS

The Scrolling SIG will be in the club workshop at *Eight Acres* for now. Meetings will also be available via Zoom. Members will receive the address of the workshop via email ahead of the meeting or they can request via an email to [woodcny@gmail.com](mailto:woodcny@gmail.com).

*Schedules subject  
to change*

## MEETINGS SCHEDULES

### WOODWORKERS SIG SPONSORED DEMOS—2023

Date	Topic	Demonstrator/Speaker
January 4 <sup>th</sup>	<b>Dust Collection</b>	Oneida Air
February 1 <sup>st</sup>	<b>Air Brushing, the Basics</b>	Jackie Yonkers
March 1 <sup>st</sup>	<b>Kumiko, the Basics</b>	David Wheat & Tom Clooney
April 5 <sup>th</sup>		
May 3 <sup>rd</sup>		
June 7 <sup>th</sup>		
July 5 <sup>th</sup>		
August 2 <sup>rd</sup>		
September 6 <sup>th</sup>		
October 4 <sup>th</sup>		
Saturday, November 11 <sup>th</sup>	17 <sup>th</sup> Woodworkers Challenge <i>All Members Plan to Participate in this Annual Competition!</i>	
Sunday in December	<i>Holiday Event — One Party for All Members</i>	

### TURNERS SIG SPONSORED DEMOS—2023

Date	Topic	Demonstrator	Workshop
January 10 <sup>th</sup>	<b>Turning a Snowman &amp; Tree</b>	Ray Smith	January 14
February 14 <sup>th</sup>	<b>Tool Fundamentals</b>	Robert Love, etc.	February 18
March 14 <sup>th</sup>			March 18
April 11 <sup>th</sup>			April 15
May 9 <sup>th</sup>	<b>Turning Boxes with Threaded Lids</b>	Jim Kent	May 13
June 13 <sup>th</sup>			June 17
July 11 <sup>th</sup>			July 15
August 8 <sup>th</sup>			August 12
September 12 <sup>th</sup>			September 16
October 10 <sup>th</sup>			October 14
Saturday November 11 <sup>th</sup>	17 <sup>th</sup> Woodworkers Challenge <i>All Members Plan to Participate in this Annual Competition!</i>		November 18
Sunday in December	<i>Holiday Event — One Party for All Members</i>		

*Continued on Page 33*



## MEETINGS SCHEDULES

Schedules subject to change

### CARVERS SPONSORED DEMOS/CLASSES—2023

Date	Topic
January 19 <sup>th</sup>	<b>Carving a Valentine Heart</b> w/ Gary Morison
February 16 <sup>th</sup>	<b>Carving Hearts—Part 2</b> w/Gary Morison
March 16 <sup>th</sup>	TBD
April 20 <sup>th</sup>	<b>Shroomspirit</b> w/Mike Bloomquist
May 18 <sup>th</sup>	<b>Shroomspirit—Part 2</b> w/Mike Bloomquist
June 10 & 11	<b>Face Carving Workshop</b> with Jim O’Dea or <b>Quilted Stocking Workshop</b> with Chris O’Dea [Fee TBD]
June 15 <sup>th</sup>	<b>Making a Knife Handle</b> w/Gary Morison
July 27 <sup>th</sup>	<b>Mushroom Gnome House</b> w/Harold Kaltenbach
August 17 <sup>h</sup>	<b>Mushroom Gnome House—Part 2</b> w/Harold Kaltenbach
September 21 <sup>st</sup>	TBD
October 19 <sup>th</sup>	TBD
Saturday, November 11 <sup>th</sup>	TBD
November 17 <sup>th</sup>	TBD
Sunday in December	<i>Holiday Event—One Party for All Members</i>
December ??	Unfinished Project Workshop & Holiday Party

### SCROLLERS SIG SPONSORED DEMOS—2023

**NOTE:** Due to a combination of factors, the Scrolling SIG will hold its in-person meetings in the club workshop space at Barb & Charlie’s. We will continue to employ Zoom to broadcast those meetings for our remote members. All are welcome to attend these sessions.

Date	Topic
February 15 <sup>th</sup>	<b>Intarsia</b> w/Sherry — Challenge: Segmented Project
April 19 <sup>th</sup>	<b>Back to the Basics</b> — Challenge: Intarsia Project
June 21 <sup>st</sup>	<b>Using Spiral Blades</b> —Challenge: Christmas Ornaments
July & August	<b>No Meetings—Get Your Projects in For NYS Fair Competition!</b>
September 20 <sup>th</sup>	<b>Undulating Ring Baskets/Simulated Baskets</b> —Challenge: Spiral Blade Project
October 19 <sup>th</sup>	<b>Scrollsaw Joinery</b> —Challenge: Baskets
Saturday, November 11 <sup>th</sup>	<b>17th Woodworkers Challenge</b> <i>All Members Plan to Participate in this Annual Competition!</i>
Sunday in December	<i>Holiday Event—One Party for All Members</i>

**Classifieds are welcome with the caveat that people notify the editor when entries are sold.**

## CLASSIFIEDS

**FOR SALE—Grizzly 2HP Dust Collector**—steel impeller. \$400. Contact Kevin Rawlings at [hostaguy@gmail.com](mailto:hostaguy@gmail.com)

**FOR SALE—General 3HP Shaper Model 40-250 (220V)** with accessories. Original owner. \$1500. Contact Rick Simmons at [rick2859@yahoo.com](mailto:rick2859@yahoo.com) or 315-876-8338

**WANTED—DRY, Live Edge Hardwood Boards.** Minimum size of 5 inches wide, 12 inches long, and at least 1½" thick. Wider and longer the better. Contact Mel Taber at (315) 487-7855 or [mtaber3@gmail.com](mailto:mtaber3@gmail.com).

**FOR SALE—Small items** from Ed Essel's shop. Contact Charlie LaPrease (315-720-7151) to discuss prices, etc.

**FOR SALE — Used bench vises.** Good quality, commercial grade. Price \$50 to \$75 each. For more info, email **Bud Millis** at (315) 297-7525/[emillis@twcny.rr.com](mailto:emillis@twcny.rr.com)

**FOR SALE — LUMBER – Kiln & Air Dried Hardwoods** (PA cherry, chestnut, maple, white oak, butternut, etc.) and some softwoods available. Also Black Walnut and English Walnut slabs available. Contact **Bud Millis** at (315) 297-7525 or [emillis@twcny.rr.com](mailto:emillis@twcny.rr.com).

## AREA LUMBER SUPPLIERS

### \*\* MEMBER OF CLUB

Also, see various offerings by members in the classifieds above as well as the links on the Wood ID & Suppliers page on the website.

### Custom Hardwood Lumber Co. \*\*

8633 State Route 104  
Hannibal, NY 13074  
(315) 564-3101 Facebook link [here](#)  
[Customhardwoodlumber@gmail.com](mailto:Customhardwoodlumber@gmail.com)

### Dexters Woodshop \*\*

6949 Kingdom Rd  
Memphis  
(315) 456-8271

### Logs to Lumber

720 Church St, Baldwinsville  
(315) 678-2151

### Memphis Hardwood Lumber

6535 Church St, Memphis (315) 689-3949  
[www.memphishardwoodlumber.com](http://www.memphishardwoodlumber.com)

### Lakeshore Hardwoods \*\*

266 Manwaring Rd., Pulaski (315) 298-6407  
191 West Main St, Victor (585) 869-5118  
[www.lakeshorehardwoods.com](http://www.lakeshorehardwoods.com)

### Kennedy Hardwood

1939 Clark Rd., Preble (607) 749-7890  
[www.kennedyhardwood.com](http://www.kennedyhardwood.com)

### Liverpool Lumber Company

201 North Willow St., Liverpool  
(315) 457-2220  
[liverpool-lumber.com](http://liverpool-lumber.com)

### Pittsford Lumber

50 State St., Pittsford (585) 586-1877  
[www.pittsfordlumber.com](http://www.pittsfordlumber.com)

### Tracy Lumber [B.H. Tracy & Sons]

550 East Genesee St., Fayetteville  
(315) 637-3174  
[www.tracylumber.com](http://www.tracylumber.com)

### Willey Lumber Company

100 Hartwell Ave, East Syracuse  
(315) 437-3344  
[www.willeylumber.com](http://www.willeylumber.com)

### Johnson Brothers Lumber

2550 Ballina Rd, Cazenovia (315) 655-8824  
[www.johnsonbrotherslumber.com](http://www.johnsonbrotherslumber.com)

### Salt City Woods, Mill & Kiln \*\*

1153 West Fayette St  
Syracuse, NY 13204  
(315) 952-1692  
[derby@saltcitywoods.com](mailto:derby@saltcitywoods.com)  
[saltcitywoods.com](http://saltcitywoods.com)

### Brown Dog Wood Products

1379 County Route 4, Central Square  
315-243-8358  
[www.Browndogwoodproducts.com](http://www.Browndogwoodproducts.com)