



# TIMBER TIMES

On the Web at: <http://www.woodcny.org>

On Facebook – WoodCNY

Volume 6, Issue 5

May 2023

The Woodworkers of Central New York is a Chapter of the [American Association of Woodturners](#)

**A Multi-Disciplinary Social & Educational Organization  
Dedicated to Advancing the Arts of Woodworking**

## MAY CLUB EVENTS

**Wednesday, May 3<sup>rd</sup> @6:30pm**  
**Woodworking SIG Demo**

**Photographing Your Projects**  
w/Dan Ware

**In Person** @ Canton Woods  
Senior Center, 76 Canton St.,  
B'ville or **Via Zoom**

**Saturday, May 6<sup>th</sup>**  
**Craft Sales for Charity at the**  
**2023 Crawfish Festival** in  
Clinton Square  
Sales 11am-7pm  
Setup at 8:00-10:30am  
Volunteers Needed for Setup  
Details Page 14

**Tuesday, May 9<sup>th</sup> @6:30pm**  
**Turning SIG Demo**  
**Threaded Boxes** with Jim Kent  
& Chad Dawson  
**In Person** @ Canton Woods  
Senior Center, 76 Canton St.,  
B'ville or **Via Zoom**

**Thursday, May 18<sup>th</sup> Carving SIG**  
**Workshop**  
**Shroomspirit – Part 2** with  
Mike Bloomquist  
Gathering Starts @ **5pm**  
Workshop Starts @ **6pm**  
Open Carving Until **8:15pm**  
**In Person** at Beaver Lake  
Nature Center, 8477 East Mud  
Lake Road, Baldwinsville

**Sunday, May 21<sup>st</sup> from 9am to**  
**12 noon**  
**Club Workshop** at Eight Acres  
Event Center, B'ville  
Exact address available to  
members and potential visitors by  
email to [woodcny@gmail.com](mailto:woodcny@gmail.com)

## PYROGRAPHY TRAINING

Several members of the club attended either or both the pyrography demonstration on Friday evening, April 21<sup>st</sup> or the workshop on Saturday afternoon, April 22<sup>nd</sup>. Both sessions were led by Sandra Sabene of the Liverpool Arts Center. The demonstration with 22 attendees was held at the Center in Liverpool. There were many questions, answers, ah-ha moments, and discussion. Saturday afternoon 17 members gathered at the Martville Pathfinder Studio retreat location for an afternoon workshop. Attendees explored and practiced with two basic types of tips available with most wood burners, the line and shading tips. Once everyone was comfortable with their tips, images were transferred to wood and everyone started to create their project. Sandra worked with each attendee as needed to develop their skills, address bad habits, and provide positive encouragement. The resulting projects is phenomenal as shown in the photo below. The training was a complete success with even some of the experienced attendees leaving with many new ideas, skills, techniques, and tips. Thanks for a great event, Sandra!



## INSIDE THIS ISSUE

Pyrography Training	1
Meeting Location	2
May 2023 Events	3-4
Club Workshop Info	4
Mike's Corner—Seam Rippers	5
Wood Carving Training w/ the O'Deas	6
Tops Needed	7
Wood Education—Dogwood	8
Beads of Courage Boxes	9
Shop Time	10
More Shop Time	11
Reserve the Date: Summer 2023 Woodworking Soiree	12
Craft Sales for Charity	12
AAW Symposium—June 1-4	13
Pyrography Class Photos	14
Show & Tell April 2023	15-8
Turners Monthly Challenge	19- 21
More Shop Tips	21
Monthly Workshop	22
Corporation & Leadership Information	23
Now Is the Time!	24
Location of Meetings	25
Sending Photos	25
Finding Equipment Locally	25
Corporation Supplies, etc.	26
Sharpening Services	24
American Association of Woodturners Info	27
In-Person Classes	27
Classes, Events & Symposiums	28
Directions to Locations	29
Meeting Schedules	30-1
Classifieds	32
Area Lumber Suppliers	32

## LOCATION FOR WOODWORKING & TURNING

The Belgium Cold Spring Fire District continues to restrict the use of the Community Room under a new policy they created in late 2022 for retaliation. As a result, we are relocating two of our Special Interest Group meetings – the Woodworking and the Turning – to a Plan B location for now – the Canton Woods Senior Center at 76 Canton St, Baldwinsville. Rather than free, this location costs us \$50-\$65 per event. The Scrollers will continue to meet at the Eight Acres shop space due to low attendance and the Carvers will continue to meet at Beaver lake Nature Center. We do have WiFi at the Canton Woods location for Zoom.

For some members, they will remember Canton Woods as it was a previous meeting location. For others, here is what you need to know, including directions.

### CANTON WOODS SENIOR CENTER, 76 CANTON STREET, BALDWINSVILLE

The Senior Center is a facility that provides a variety of activities and for area seniors. Residents living in the Towns of Lysander and Van Buren (including the Village) may join for free. There is a small fee for others. *Meals on Wheels* for the area runs out of this facility. Seniors may also benefit from Peace lunches and other programs that are provided.

The Center is in the Village but on the south side of the River off Downer Street which is Rt 31.

- ◆ From Rt 690 North/South, you take the exit for Downer St/Route 31 and head east 1.1 miles and turn right onto Canton St. The Center is on the right about 1400 feet south.
- ◆ From the center of the Village (*the 4 corners*) where Rts 370/31 meet Rt 48, turn left south onto Rt 48. At the second traffic light, turn right onto Downer St and make the next left onto Canton St.



## UPCOMING EVENTS

### WOODWORKING SIG PHOTOGRAPHING YOUR PROJECTS WEDNESDAY, MAY 3<sup>RD</sup>—6:30PM

We create a beautiful project but then want to photograph it to record it for our portfolio, showcase it for sale, or just show it off to our family and friends. Are there tricks to photographing our projects? **Dan Ware** will demonstrate and talk about what you should and should not do on May 3rd in this demonstration! This is a must attend session for all members!

This session will be available as a hybrid session – both in-person and via Zoom. We hope many of you will join us in-person and bring your *Show & Tell* items. All members will receive a reminder with the Zoom link a few days before the event. Can't make it or viewing via Zoom but have projects to show? Send an email with photos and a description to [woodcny@gmail.com](mailto:woodcny@gmail.com) no later than 3pm on May 5<sup>th</sup> to be included in the slide show! Earlier is very much appreciated!



### TURNING SIG—THREADED BOXES TUESDAY, MAY 9<sup>TH</sup>—6:30PM

Many turners love making small boxes as gifts or to sell. The challenge is making boxes with a threaded lid. **Jim Kent** will demonstrate during the May 9<sup>th</sup> Turning SIG meeting how he cuts threads on lidded boxes to add a distinctive element to a box and allow the lid to be screwed on and off repeatedly and securely. This technique can easily be replicated to add threads to other objects such as jigs and toys. Join us to see how Jim does it!

The **Monthly Challenge!** Anyone who attends this session, can enter their **whiskey glass** created after the April 11<sup>th</sup> demo. Attendees will vote during the break for their *People's Choice* recipient who will receive a gift card. Another *Challenge Participant* will also receive a gift card.

This session will be available as a hybrid session – both in-person and via Zoom. We hope many of you will join us in-person, handle your membership renewal, and bring your *Show & Tell* items. All members will receive a reminder with the Zoom link a few days before the event. Can't make it or viewing via Zoom but have projects to show? Send an email with photos and a description to [woodcny@gmail.com](mailto:woodcny@gmail.com) no later than 3pm on May 9<sup>th</sup> to be included in the slide show! Earlier is very much appreciated!



### TOOL RAFFLES RETURN

Our popular tool raffles returned in February. Our first raffle will run for 3 months and it is for an [Earlex Spray Station HV5500](#). Tickets are \$1 each and 6 for \$5. We will draw a winner at the May 3<sup>rd</sup> meeting.

Can't make it to the meeting but want to enter? Send a check to WWCNY, 3405 Patchett Rd, Baldwinsville, NY 13027. Your tickets will be added to the collection.





## CLUB WORKSHOP SUNDAY, MAY 21<sup>ST</sup> 9AM-NOON



The next club workshop will be held on the **Sunday, May 21<sup>st</sup>**. This is an odd date due to Charlie's training sessions. We are hoping for warm weather so all members may attend. The workshop is held at the large garage at Charlie & Barbara's home a location affectionately known as the *Eight Acres Event Center*. One area of the garage is heated by a wood stove. This area contains 10 lathes and a scrollsaw, all owned by the club. During the colder months, the workshops are generally restricted to turning instruction but we open it up to all members during the warmer months. If a member wishes instruction on other topics, they can request it and if it cannot be handled on the normal workshop day, Charlie will work with them to schedule another time.

During the workshop, you can purchase sandpaper, Anchor Seal, or other consumables that the club purchases in bulk to help the members. You can also purchase wood from Charlie's huge stash. These items can be purchased at ANY time. You do not have to wait for a workshop day. Contact Charlie at any time either at [8acreswood@gmail.com](mailto:8acreswood@gmail.com) or 315-720-7151 to arrange a time to purchase whatever you need.

**Where?** The exact address for the club workshop is sent to all members by email before the event. It is located near the Northwest YMCA east of Baldwinsville.

**NOTE:** We ask that you register by 5pm on May 20<sup>th</sup> so we know you are planning attend and what you plan to do during the workshop – email [woodcny@gmail.com](mailto:woodcny@gmail.com).

## CARVERS SIG – SHROOMSPIRIT—PART 2 THURSDAY, MAY 18<sup>TH</sup>—5-8PM



The Carving SIG will meet on Thursday, May 18<sup>th</sup> (In-person only) and hold a workshop where attendees will learn to carve a Shroomspirit with **Mike Bloomquist**. This is the 2<sup>nd</sup> part of the class but feel free to attend even if you did not attend in April.

Gathering will start at 5pm and instruction should start by 6pm. We have the room until 8:30pm. This should be another excellent fun project! Don't forget your **Show & Tell** items also.

The Carvers meet in the large Community Room at the *Beaver Lake Nature Center, 8477 East Mud Lake Road, Baldwinsville, NY. Directions on page 31.*

Not a club member but want to carve? There is a \$5 one-day membership fee. We have carving kits you can borrow during the event.

## SCROLLERS SIG – USING SPIRAL BLADES WEDNESDAY, JUNE 21<sup>ST</sup>—6:30PM



The Scrolling SIG will meet next on Wednesday, June 21st when the topic will be working with spiral blades. Members are asked to bring their scrolled tops and other donations for our craft sales to this meeting.

The event location for now is the shop at 8Acres and we will also broadcast via Zoom. If you have **Show & Tell** and plan to attend via Zoom, please send photos and descriptions to [woodcny@gmail.com](mailto:woodcny@gmail.com) by 3pm on the 21<sup>th</sup> to be added to the slides. Members will receive the shop address along with the Zoom link by email the week of the event.

## MIKE'S CORNER SEAM RIPPERS!

Mike Vecellio shares a variety of techniques he's learned with other members whenever possible. Here he talks about making seam rippers. *Your articles are welcome anytime.* Please send to [woodcny@gmail.com](mailto:woodcny@gmail.com).

If you would like a simple but rewarding project you might want to try creating a seam ripper. My family has quite a few quilters and others that sew, so when my wife, the quilter, asked me to make her a few I went to work. She knew that they could be made because my friend, *Doug North*, had made her one.

I headed to my favorite website to buy kits – [Exotic Blanks](#) – to see what kits they had to offer. It seems that they have a few types so I ordered the ones that have an stiletto (awl) on one side and a seam ripper on the other.

These are actually Penn State Industries kits, but Exotic Blanks sells them at the same price. If you buy 10 or more you get a discount. Also, you get a bag of peanut M&Ms with your order! What more could you want?

Figure 1 (top right) shows what comes in the kit. There is a 3 $\frac{1}{8}$  inch 8mm tube, the stiletto (awl) and ripper ends, and two retaining springs.

The blank preparation is exactly the same a preparing a single tube pen blank.

**IMPORTANT TIP:** Lately when I drill with my 8mm bit, I noticed the hole is too small for the 8mm tube. This is true for my 8mm pens also. To compensate for this, I ream out the hole with an 8.37mm bit that is also known as a *P-size* bit. I am not sure why this is happening. My guess is that by drilling on the lathe the hole is so precise a little wiggle room is

needed. A secondary drilling/reaming is also a good idea if you are planning on painting the inside of a translucent acrylic blank.

Turning and finishing the blank is also the same as a single tube pen blank. For wooden blanks I use [Gluboot](#) CA glue for the finish.

There are only two steps in assembling the kit. First, make sure there is no glue or other residue inside the tube. Next, the retaining springs need to be inserted into the ends of the tube.

The first one I did was a little tricky, but after assembling one, it was easy. You need to squeeze the retaining ring into a small round circle being careful not to crease it. Then insert it into the end at least  $\frac{2}{3}$  to  $\frac{3}{4}$  of the way into the tube before you let go. Make sure you insert the solid end first. Then, finish pressing it into the end flush.

People must have been putting the wrong end in first because at the bottom of the instructions it says:

*“If the ripper assembly is held by the spring when the ripper is out, but does not stay when the ripper is being stored inside, then you ignored the multiple times this instruction said to insert the solid side of the spring first.”*

Figure 2 (bottom right) shows four(4) seam rippers that I made for my wife and relatives.

This is a fun project for both beginning and advanced turners looking for a simple project to score points with a sewer!



## WOOD CARVING TRAINING

### FACE CARVING STUDY STICK w/JIM O'DEA

### QUILTED STOCKING w/CHRIS O'DEA



#### FACE CARVING STUDY STICK with Jim

**When:** Saturday and/or Sunday June 10-11 8:30am-4pm  
**Cost:** \$25 per day up to 10 students/day

#### QUILTED STOCKING with Chris

**When:** Saturday June 10 8:30am-4pm

**Cost:** \$20 up to 8 students

**Where:** Beaver Lake Nature Center Meeting Room

**How:** Email to Reserve Spot to [woodcny@gmail.com](mailto:woodcny@gmail.com)  
 then check to **Woodworkers of CNY** to  
 3405 Patchett Rd, Baldwinsville, NY 13027

The Carving Special Interest Group is sponsoring some hands-on training with Nationally known carvers, **Jim and Chris O'Dea**. They are here for two (2) days in June. Jim will also have carving supplies for sale that ALL members may take advantage of. He is expected to have the knife blanks for the June 15<sup>th</sup> club session. The times for those sales will be announced later.

**Jim O'Dea** will teach attendees how to carve faces better. He will teach on 2 days, Saturday and Sunday, June 10-11. You can attend just one day or attend both days. The price (\$25) is per day and the class size is limited to 10 each day. More info about the class is below.

**Chris O'Dea** will teach up to 8 students how to make the Quilted Stocking on Saturday, June 10<sup>th</sup> for \$20. Details below.

**Face Carving Class Info:** This class is an introduction to face carving for the beginning woodcarver with little or no experience doing human faces. It is also useful to those that are not satisfied with the faces they are currently doing and those just looking for a different way. Students will have the opportunity to follow a methodology in developing a human face using just a knife. But, if you have gouges bring them ALL. Jim will show you where they can work better or faster. The emphasis of the study stick class days will be on the process, not the artistic nature of the carving. Jim does not cover very much about expression, gender differences, racial differences or anything else during this time, rather he is trying to get the student to carve a face that looks human. Practice and application can then develop the artistic nature of your carving. Attention will be paid to how you use the tools to get *clean* cuts, precise cuts, and how not to cut yourself. Each student will carve their own step-by-step study stick, with each step numbered, which will lead them through the process of *blocking* out a human face on the corner of a 1½" square block about 12" long. Jim spreads the steps out and includes as many steps as possible to provide clarity of the step. He uses 2 of these sticks to block out the face - completing the nose and an open mouth with teeth & tongue. You will also do eyes step-by-step on another stick. Ears are done on a smaller stick especially prepared for doing ears. Four different sticks in all.

**Quilted Stocking Class:** The stocking is ornament size (4" x 1") and is showing in the photo. Students should bring a knife, V-tool, and woodburner with tips. There will be some tool loaners available. She will have additional blanks available for projects that use the same techniques taught in this class.





## TOPS NEEDED!

Looking ahead to the 2023 NYS Fair, each year the club sells tops to the attendees as a fundraiser for a couple local charities. We sell enough that we need a stockpile of **500-600 tops!**

Tops can be turned, scrolled, or even made on a laser/cnc!

Don't know how to make a top? Come to a turning workshop to learn! Charlie and others will be happy to show you! Here are three YouTube videos to check out: [Making a Top](#)

[Wood Magazine](#)

[Jason Geiser](#)

[Gwinnett Woodturners](#)

Mike Vecellio provides some great instructions for making tops in two of his past columns – [August 2020 & March 2023](#). Check those out!

Yes, tops can be scrolled also. There are two methods. The first is to create a compound cut spinner using a pattern from Al Baggetta that can be found [here](#). The pattern is a distance down the page. He has a video of the process on YouTube [here](#). The second method is to create a round disc and put a dowel with a point through the center. Any round disc can be made that is about 2-3" in diameter. A sample set of discs are in a pattern on dmidea.eu in the toys category [here](#). Print the discs at about 80%. Steve Good also has one on his website [here](#); search for *toy top*. As stated, any round disc can be used to create a top. No special designs need to be added. Be creative!

**Finishing?** The buyers love it when you add color to plain tops. Magic markers work fine! Please no glitter!

**What Do I Do With Them?** Bring to any meeting or event. If you can't make one, you can always drop them off at Eight Acres, just let us know you are stopping by!

**The club sells about 600 tops during the New York State Fair to our many visitors.**

**All proceeds from these sales are presented to a local non-profit that provides services to children!**

***Time to start making tops! Bring to any meeting, workshop, demonstration, or event!***



## WOOD EDUCATION — DOGWOOD

Spring brings out the flowering trees, some of which can take your breath away. One such tree is the dogwood.

**Dogwood** (*Cornus florida*) is grown in eastern North America. It is a beautiful and versatile ornamental tree, the most popular species being the Flowering Dogwood. This species is known for its stunning white to light yellow flowers. There are also species that have a variety of pink flowers. Grown best in dappled shade areas where taller shade trees provide protection from direct sun rays, they can add interest to your landscape if given enough water to grow.

Most boards and blanks produced from dogwood are composed primarily of sapwood rather than heartwood. Narrow heartwood is a reddish brown. Wide sapwood is cream to pale pinkish in color. The wood, unlike the flowers, has no characteristic odor.

The wood of the flowering dogwood has a reputation for its toughness and shock resistance. Stiff and finely textured, the wood weighs as much as hickory, yet it is harder! When used as a chisel handle, dogwood resists crushing and mushrooming from hammer blows. Its toughness is appreciated in a variety of applications, though its poor dimensional stability means that its use is usually restricted to unglued/unjoined standalone components where its expansion and contraction can occur freely.

Flowering dogwood is a small deciduous tree growing to 33ft tall, often wider than it is tall when mature, with a trunk diameter of up to 1ft). A 10-year-old tree will stand about 16ft) tall. The leaves are opposite, simple, ovate, 2.4-5.1in) long and 1.6-2.4in) broad that turn a rich red-brown in fall.

Flowering dogwood attains its greatest size and growth potential in the Upper South, sometimes up to 40 feet in height. At the northern end of its range, heights of 30-33 feet are more typical. Hot, humid summer weather is necessary for new growth to harden off in the fall.

The flowers are individually small, with four, greenish-yellow petals. Around 20 flowers are produced in a dense, rounded flower-head. The flower-head is surrounded by four conspicuous large white, pink or red bracts (*not petals*).

The fruit is a cluster of two to ten separate drupes which ripen in the late summer and the early fall to a bright red, or occasionally yellow with a rosy blush. They are an important food source for dozens of species of birds, which then distribute the seeds

Janka Hardness: 2,150 lb,  
Average Dry Weight: 51 lbs/ft<sup>3</sup>  
Specific Gravity: 0.64, 0.82  
Tangential Movement: 11.3%  
Radial Movement: 7.1%  
Volumetric Shrinkage: 19.9%

### ***FUN FACTS:***

- ◆ Dogwood wears smoother with age so it is great for knitting needles, spools, bobbin heads, skewers, golf club heads, pullies, and sled runners
- ◆ Also called boxwood & bunchberry.
- ◆ State tree of Virginia and Missouri and state flower of North Carolina.
- ◆ According to the story, it was the dogwood tree that provided the wood to build the cross on which Jesus was crucified. Because of that role, it is said that God both cursed and blessed the tree.

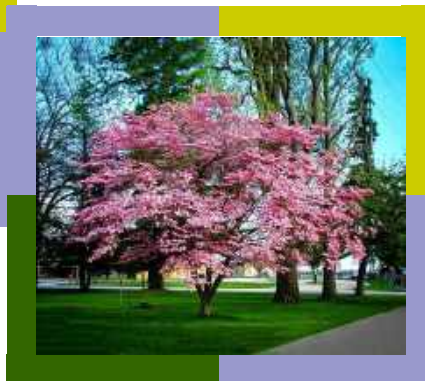



## BEADS OF COURAGE BOXES

**B**eads of Courage is a non-profit organization that is dedicated to improving the quality of life for children and teens coping with serious illness, their families, and the clinicians who care for them. Children being treated for life-threatening illnesses are given beads as they undergo a variety of treatments. Boxes are one of the vessels in which they keep their beads.

The Syracuse Joslin Diabetes Center contacted the club requesting that our members make boxes for distribution to kids undergoing treatment for diabetes at the Center. They are looking for boxes of any type whether turned, scrolled, carved, or assembled using traditional woodworking. Members are encouraged to build and donate one or more boxes to fill the Center's urgent needs. Doug North, our president is managing our involvement in the program. Bring the completed boxes to meetings/other events or arrange for their receipt by Doug ([dnorth@twcnj.org](mailto:dnorth@twcnj.org) or 315-753-1121). We want to track and photograph each donated box.

**T**here are some guidelines for size, finish, etc. We recently clarified the sizes so these are revised guidelines.

### Wood Thickness & Weight:

- ♦ The boxes should not be heavy or bulky. Wall thicknesses should be ¼" to not more than ½". Please, not super thin and delicate.

### Dimensions:

- ♦ **Turned Boxes: Around 6x6" and not larger than 8x8"**
- ♦ **Flatwork Boxes: Not smaller than 6x6x3" and not larger than 8x8x3"**

### Base & Lids:

- ♦ Box bases should be wide enough so the box is stable & does not tip over easily
- ♦ Lids should be easy for small or ill children to remove or lift.
- ♦ Any finials should be easy for a small child to grasp and not too elaborate so they don't break

### Design Consideration:

- ♦ The boxes should be able to transition with the child into adulthood and be a keepsake for many years as the patients life with the diagnosis for a lifetime.
- ♦ Avoid excessively elaborate designs that may easily break or be damaged.
- ♦ If possible, incorporate one of the *Beads of Courage* beads into the box. See Barbara at any meeting to obtain one. The club purchased the beads

### Finishes:

- ♦ Please use a safe, non-toxic finish.
- ♦ Do not use finishes like linseed oil that take a long time to outgas.
- ♦ Refrain from painting the boxes. Instead, highlight the beauty of the wood with clear varnish, a stain, and/or wood burning.

beads  
of COURAGE®



The folks at the Joslyn Center are desperate for boxes. Please step up and make one or two (or more!).



## SHOP TIME!

Shop Time is our column that brings you techniques that you can use in the shop. If you have some tips to share, please send to [woodcny@gmail.com](mailto:woodcny@gmail.com).

### Foldable Watercolor Set

Looking to add color to your projects with minimal hassle? Attendees at the pyrography demo on Friday evening learned about this great small folding watercolor set with 42 vibrant colors along with three brushes. You add water to the brushes – 2 round tip and 1 flat tip – and then paint your projects using the water in the brushes to activate the paints.

The price? About \$20.00. There are a couple on Amazon with this one by Artsy having 3 brushes. You can also purchase other brush sets of different sizes.



### Dowel Cutting Jig

Many of us use dowels in our woodworking projects. Cutting small pieces of dowels to the right length can be tricky, if not dangerous. This tip presents a jig that safely solves the problem.

Here's a jig that will make "short work" of accurately cutting dowels into small pieces with a hand saw. It can be used on three common sizes of dowels (1/4", 3/8" and 1/2"). And the dowels are cut without any splintering, in lengths from 1/4" to 2" long. Best of all, the jig is easy to make and it has just two parts: a hardwood body and a hardboard stop that pivots on a screw.

To make the jig, first drill three holes along the edge of the body. Then cut the kerfs out with a back saw. Each kerf is labeled so you can quickly establish the length of the dowel you want to cut. Then attach the stop to the jig with a woodscrew.

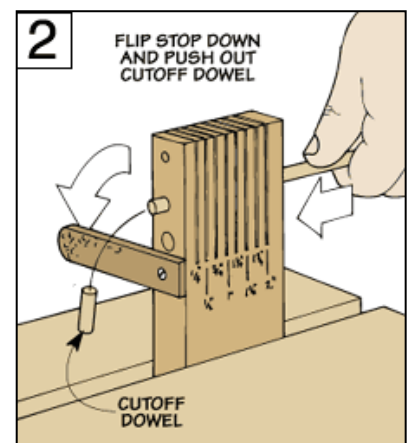
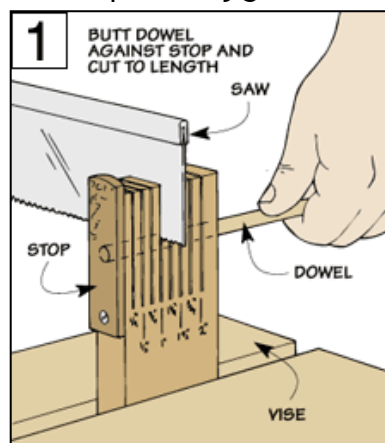
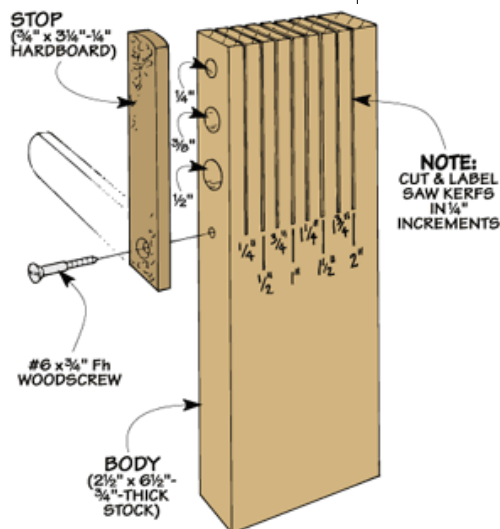

## MORE SHOP TIME!

### Low Tech Drill Guide!

If you count speed, accuracy, and convenience important in your shop, a drill press fits the description. But you can still get good results with a hand-held drill as well.

To do this, you can cut multiple drill guide blocks from a length of 2x2 with grooves (to match drill bit diameters) cut in opposite faces (see *Figure 1*). By keeping the bit captive on three sides, the block all but guarantees correct alignment. The end of the block can also act as a depth stop against a bit collar or the drill chuck itself.

After cutting the blocks, the key to getting accurate holes is to locate a sharp brad-point bit at the hole center. Then, move your drill guide block into position (see *Figure 2*). Snugging the guide block up against the drill bit automatically aligns the bit for straight drilling. And using a stop collar lets you cut a hole at the desired depth (see *Figure 3*).

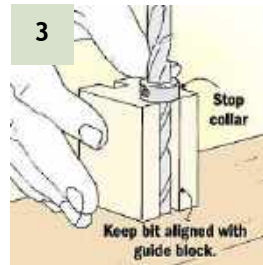
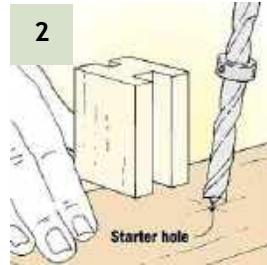
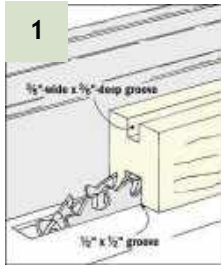

## Miter Joint Corner Clamp

Gluing a miter joint is a challenge. There just isn't an easy way to clamp it. The store-bought clamps didn't always pull the joint together. Here's a shop-built corner clamp that uses wedges to push (or press) the mitered pieces in place.

Looking at the photo at the right and drawing below, you can see that this corner clamp uses a piece of plywood as a base. Then a square block and two cleats are glued and screwed on top.

What's important here is that the inside corner of the square block is exactly 90°. Then align the inside edge of each cleat parallel with the inside edges of the block.

A pair of wedges sized to fit between the workpiece and the cleat does all the work. They apply pressure in two directions at the same time. When the inside wedge (the one contacting the mitered piece) is tapped forward, it pushes the joint tighter together and firmly holds the pieces in place while the glue dries.

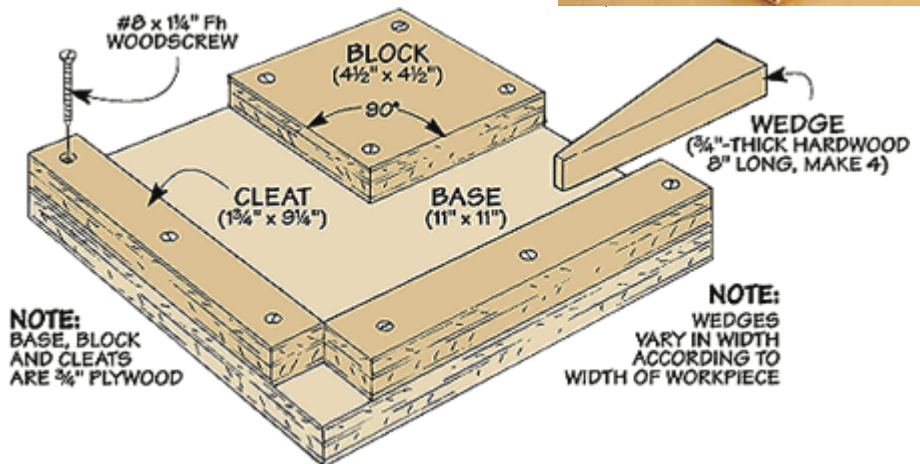

PHOTO BY JEFFREY HARRIS





## SUMMER 2023 WOODWORKING SOIREE RESERVE THE DATE — SATURDAY, JULY 22!

**WHAT?** A full day *workshop* with a variety of demonstrations and opportunities to participate and learn new techniques.

**WHEN?** Saturday, July 22  
9am to 4pm

**WHERE?** Eight Acres Event Center,  
the club's workshop location

**WHAT'S PLANNED?** Demonstrations on a variety topics, some of which can't easily be shown at a meeting. Opportunities for you to learn some new skills, spend time making tops, sharpen your tools, learn to use your Dremel better, etc.

### What Can You Do?

Offer to help with planning & organizing

Offer to be a demonstrator

Suggest topics for demonstration

Plan to attend

Contact Barbara at [woodcny@gmail.com](mailto:woodcny@gmail.com)



## CLUB CRAFT SALES FOR CHARITY AT 2023 CRAWFISH FESTIVAL SATURDAY, MAY 6<sup>TH</sup> — SALES 11AM-7PM

**T**he club sells a variety of craft items donated by members at 3-4 shows per year. This year we are selling at the Crawfish Festival being held in Clinton Square on Saturday, May 6 with sales from 11am to 7pm. Setting up starts at 8am and help is needed for this part of the event. We could also use help to pack up at 7pm. If you can help, please contact Barbara at [woodcny@gmail.com](mailto:woodcny@gmail.com) or 315-345-5381.

If you have items for donation, please get them to Barbara before May 6th so they can be handled. Our next 2023 sale is not until September 9-10 at Beaver Lake.



Our Booth at the 2022 Lion's Club Show In Oswego

All proceeds from these sales go to local children's charities. About \$4600 was donated in 2022 from these sales to two (2) charities. Since its inception in 2006, our efforts donated about \$50,000 to a variety of charities. If you are aware of a worthy charity, please send a note to [woodcny@gmail.com](mailto:woodcny@gmail.com) so the Charities Committee can check it out.

## AAW SYMPOSIUM—JUNE 1-4, 2023

The American Association of Woodturners (AAW) holds a multi-day symposium on a yearly basis. This event is held in different locations each year, generally rotating across the country. This year, the event is being held in Louisville, Kentucky from June 1-3.

**What Happens at the Symposium?** Attendees can learn from over 80 live in-person demonstrations; explore the many different products available from a myriad of vendors in the tradeshow; view an incredible and widely diverse collection of projects in the gallery, all created by show attendees; and talk with and learn from many, many other turners who are also attending.

**Where Exactly Is It Being Held?** The Kentucky Expo Center which is just south of Louisville, near the airport. It's about an 11 hour drive from Syracuse.

**What Does it Cost?** For members of AAW, the cost is \$355 through May 1 and \$410 after. If you are not a member of AAW, the cost is higher. If you are serious about turning, joining AAW is a smart investment.

**What About Hotels?** According to the Symposium website ([here](#)), the Crowne Plaza at the Airport is sold out but AAW has a block of rooms at the Tru by Hilton nearby.

**Are There Club Members Attending?** Yes, there are a few, including Doug North, our president.

### Who Are the Demonstrators?

Helen Bailey	Jason Breach	Pat Carroll	Jim Echter
Roberto Ferrer	Lynne Hull	Phil Irons	Ulf Jansson
Mauricio Kolenc	Kristin LeVier	Nicole MacDonald	Joss Naigeon
Laurent Niclot	Seri Robinson	Dick Sing	Curt Theobald
Jacques Vesery	Elizabeth Weber	Derek Weidman	

**What Are the Topics for the Demos?** Look at the Symposium website for the schedule and topics. There are too many to list here.

**I'll Be Lost!** If you have never attended a Symposium, it is suggested that you attend the *First-Time Attendee orientation* which is held on Thursday, June 1 starting at 4:30pm. Then, make sure that Doug has your phone number so you can meet up with him and others. There are several networking and social events over the three days.

**What Else?** Attend the live auction online Friday from 5:30 to 7pm. You won't believe what you will see there! Anyone can connect to this auction and it is worth checking out!

*Joining the AAW is a great idea. There are varying levels depending if you want your Journal mailed or viewable only online. See page 25 for more details on joining!*





## PYROGRAPHY TRAINING—MORE PHOTOS





## SHOW & TELL APRIL 2023

Here are the projects displayed or sent in separately during April for *Show & Tell*. As usual, you can always send photos and descriptions of your recent projects to woodcny@gmail.com any time during the month.



**Jim Ruddock**  
*Beads of Courage Boxes*  
 Cherry Rectangle (top)  
 Walnut & Maple Segmented with  
 Purpleheart Knob  
 Watco or Mineral Oil & Buffed



**Terry Dote**  
 5 Small Boxes  
 Fiddle Back Maple, Cherry,  
 & Butternut



**Kenn Pickard**  
 Adirondack  
 Pack Basket  
 Made During the  
 Farm Show



**John Petzke**  
 Soccer Plaque  
 Love You Compound Cut



**Rod Castle**  
 Antique Peppermill & Salt  
 Shaker Set  
 Black Walnut & Bloodwood  
 Tung Oil



**Jim Farrell**  
 American Beauty Pens  
 Friction Polish  
 Ice Cream Scoops & Bowls  
 Wipe-On Poly / Walnut Oil



**David Wheat**  
 Plant Starter  
 Jig



**Mike Vecellio**  
 Ice Cream Scoops  
 Quilt Fabric + Ash & Maple  
 Alumilite  
 Long Pens  
 Purpleheart, Red Heart,  
 Maple, Walnut  
 CA Finish

# SHOW & TELL APRIL 2023, PAGE 2

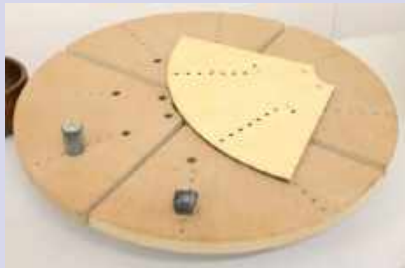

**Bruce Meissner**  
MDF Cole Jaws



**Dave Grant**  
Ring Tool  
Ash Dyed & Gilded Candlestick  
Holly Dyed Box  
Segmented Beads of Courage Box  
Dyed Ice Cream Scoop  
Spalted Scoop  
Walnut Cutting Board



**David Allen**  
Ash & Basswood Mallets  
First Turning Project



**Scott Davis**  
Tanker & Pot  
Metallic Paint



**Scott Chester**  
Walnut Bowl  
Walnut Oil  
Wood From Family in Midwest



**Ed Siegel**  
Walnut Yarn Bowl  
Wipe-On Poly



**Jim Yonkers**  
Walnut Topped 'Sewing' Table  
Cedar Boxes  
Assorted Bird Houses (for craft sales)  
Squirrel Feeder  
Steam Punk Platter Holder





# SHOW & TELL APRIL 2023, PAGE 3



**Doug North**  
Ash Bowl  
Turned at Maker  
Faire



**Barbara Raymond-LaPrease**  
Variety of Projects / Two-Layer Jungle Puzzle



**Arlene Schlueter**  
Wood Intarsia of Redwood,  
Pine & Tupalo  
Basswood Sun



**Harold Kaltenbach**  
Cottonwood Bark Houses



**Robert Ward**  
Wedding Plaque (3/8" Oak)  
Business Sign (1/2" Live  
Edge Pine)  
Dog Memorial Photos  
Including Client Display  
(1/2" Maple)





# SHOW & TELL APRIL 2023, PAGE 4



**Gary Morison**  
Cottonwood Bark Gnome Home,  
Nightlights, & Ornaments



**Elaine Negrotto**  
Bass Robin



**Bob Lake**  
Basswood  
Solider



**Dave Weir**  
Cottonwood Bark  
Houses  
Basswood  
Characters



**Frans Seiger**  
Variety of Small Heads for  
Bottle Stoppers, etc.

## QUICK TIP: FINISH PROTECTOR

**E**ver have a finely sanded or finished surface disfigured by just a slip of a screwdriver? It need not happen again if you remember this trick. Simply drill a hole the exact size of the screwdriver you're using in a piece of thin stock (*1/4" plywood works well for this*), and then clamp it in place over each hole before you begin fastening.

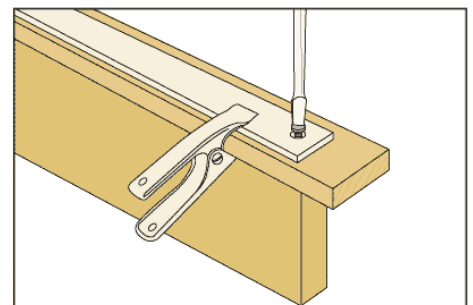

## MONTHLY CHALLENGE

Returning at the February 2023 turning meeting was the Turners **Monthly Challenge**. Turners are challenged to make a project based on the previous month's demonstration. They display their projects with a number and during the break attendees vote on the *People's Choice*. Votes are counted and the member is given a gift certificate. A *Participant* drawing is also held.

For the March 2023 meeting, the Monthly Challenge was a **Spindle Project**. Due to the snowstorm, the March meeting was held via Zoom so the projects were presented at the April meeting. For the April 2023 meeting, the Monthly Challenge was a **Bowl**.



### People's Choice



**Dave Grant**  
Ash Dyed & Gilded  
Candlesticks

### Unique Spindle Project



**Charlie LaPrease**  
Apple Lidded Box



**Doug North**  
Walnut & Poplar  
Penguin

**Larry Prunotto**  
Lilac (?)  
Vase



**Rod Castle**  
Lignum Vitae Magic Wand



**Ed Siegel**  
Purpleheart Yad



**Ray Smith**  
Practice with Skew on Maple

**Bob Santore**  
Ash Mallet



**Mark Lockwood**  
Maple, Cherry, Walnut Ornament



**Mike Vecellio**  
Ash & Walnut Tool Handles

# MONTHLY CHALLENGE, PAGE 2

## Bowl Project

### People's Choice



**Larry Prunotto**  
Two Burl Bowls  
Osmo & Wipe-On Poly



**Mike Vecellio**  
Sapele, Ash, & Cherry Bowls  
Acks Finish



**Charlie LaPrease**  
Ash with Osmo



**Scott Davis**  
Firewood with Oil



**Doug North**  
Cherry with Walnut Oil



**Mark Lockwood**  
Locust & Hickory  
Friction Polish



**Bob Santore**  
Ash with Linseed Oil & Beeswax



**Ray Smith**  
Red Oak & Butternut  
Acks Finish



**Ed Siegel**  
Walnut with Mineral Oil  
& Beeswax & Acrylics



## MONTHLY CHALLENGE, PAGE 3



*Scott Davis*  
Oak  
Osmo



*Paul Depew*  
Ash  
Turning Paste

## MORE SHOP TIPS!

### Flattening Waterstones



It's hard to beat the fast-cutting action of a waterstone for sharpening chisels and other tools. The price you pay, however, is periodic maintenance. Sanding screens are a great way to flatten a waterstone. But what can you do when you're in a hurry and don't want to deal with the mess of using a screen and water?

Here's a quick, easy way to flatten a waterstone in a pinch. Find a cement block (or even a step) that's relatively flat. Then sprinkle water on the rough face of the block and scrub the stone back and forth a few times. You'll get a passable cutting edge in no time.



### Putty Trick



When filling some nail holes with putty, by mistake you may smear the putty around without too much thought. This can cause problems if the putty is lighter than the wood around it, which results in large ugly blotches (instead of tiny nail-sized spots). Fortunately, there is a better way to fill the holes with less mess.

Before even picking up the hammer and nails, first apply a strip of masking tape. Then nail and set the heads like you normally would.

Finally, force the putty into the holes and remove the tape. The small *bump* of putty that remains can be easily sanded away.



**REMINDER**  
May Workshop is  
**SUNDAY, May 21st**

## APRIL 2023 WORKSHOP

The warm weather allowed us to open up the April 2023 club workshop to all members. We had a collection of turners, a group of carvers, and a bunch of members stop by for consumables. Here are the photos from that event.





## WOODWORKERS OF CENTRAL NEW YORK

Membership in the Woodworkers of Central New York, Inc. is open to anyone interested in all genres of woodworking.



Membership covers all Special Interest Groups – Carvers, Scrollers, Turners, & Woodworkers. No additional fee is needed to participate in these Committees unless there is a workshop fee.

There are several types of members:

- ◆ Individual Membership: \$25
- ◆ Family Membership (all living at the same address): \$35
- ◆ Junior Membership (Ages 8-17): Free with adult membership
- ◆ One Day Membership: \$5
- ◆ Honorary Membership: Board Selection

Membership applications are available on the website [www.woodcny.org](http://www.woodcny.org).

Badges are an additional \$9 per person with a \$2 charge to mail the badge.

The Corporation leadership, with contact information, is listed right as a reference. Feel free to contact any club leader to ask questions, suggest programs, or deal with issues.

You should have an active email address if you are a member as the leadership sends many member communications via email as well as this newsletter. To read the newsletter you need to have a PDF reader product such as [Adobe Acrobat Reader](#) installed on your computer.

Adobe Reader is free. Due to its size, we prefer not to send newsletters by mail unless specifically requested.

The Woodworkers of CNY was formed in September 2017, to combine the three existing woodworking groups in Central New York into one consolidated entity. Four Committees of the Corporation (aka Special Interest Groups) focus member's attention on three specific genres—carving, scrolling, & turning—as well as the broader, all-encompassing general woodworking area. Members may attend any of the meetings at no additional charge (unless there is a project or speaker charge).

The Woodworkers of CNY was reaccepted as a chapter of the American Association of Woodturners (AAW) in May 2018. We encourage you to join AAW as it is an excellent organization with great resources as a member. Membership in AAW costs either \$56 for an online only or \$68 for a paper-based membership. Each membership includes the 6 issues of the journal, *American Woodturner*, with the online membership receiving it only online. You also have access to a large collection of online resources such as the publication *AAW Fundamentals* which is published on the off months from the journal.



AAW is an international organization of over 14,000 members of varying woodturning skills. In addition to receiving current issues of the journal, *American Woodturner*, membership also provides online access to all past issues of the Journal from 1986 forward. Access to a Resource Directory is also available only to members. Members of AAW also receive savings of up to 50% on AAW merchandise, including project books, DVDs, logo apparel, and more. Members can apply for an educational opportunity grant whereby an individual can receive compensation toward woodturning education for expenses such as tuition, registration, travel, lodging, meals, etc. They can also apply for professional outreach program fellowship grants to encourage creative growth or research, or to provide inspiration for new directions in turned wood art. The AAW Forum is also available to members as are other restricted articles and resources on the AAW website. Members receive a discount on registration for the annual Symposium which is in Louisville, Kentucky in 2023. Check out the AAW website - [www.woodturner.org](http://www.woodturner.org).

**Woodworkers of Central  
New York, Inc.**  
3405 Patchett Rd  
Baldwinsville, NY 13027

### Woodworkers of Central New York, Inc.

#### Leadership

[Doug North](#), President  
(315) 753-1121

[Larry Prunotto](#), Vice President  
(315) 652-3605

[Barbara Raymond-LaPrease](#),  
Secretary (315) 345-5381

[Brad Rees](#), Treasurer  
(315) 391-2723

#### Special Interest Groups Chairs

[Gary Morison](#), Carvers  
(315) 327-9157

[Robert Ward](#), Scrollers  
(315) 506-8305

[Mark Anastas](#), Turners  
(315) 863-4483

[Charlie LaPrease](#), Woodworkers  
(315) 720-7151

#### At-Large Board Members

[Kerry Kopkey](#) (315) 593-6914

[Robert Love](#) (315) 297-4224

[Bruce Meissner](#) (315) 699-3671

[Rod Castle](#) (315) 638-2659

[Todd Reilly](#) (315) 263-3410

[Arlene Schlueter](#) (315) 720-6633

[Mel Taber](#) (315) 487-7855

[Paul Tennant](#) (315) 676-3469

#### Board Committees

*Financial Oversight*  
Larry Prunotto (chair)

*Charitable Giving*  
Susan Allen (chair)

*Nominating*  
Chad Dawson (chair)

*Web & Social Media*  
Robert Love (chair)

*New York State Fair*  
Barbara Raymond-LaPrease (chair)

*Facebook*  
Todd Reilly

*Newsletter Editor*  
[Barbara Raymond-LaPrease](#)





We are ordered some of the Ikea ice cream scoops for members make wooden handled scoops for our sales. They are available in the workshop.

Remember We have small eye hooks available to purchase!  
100 in Brass or Silver for \$1.00

## Now Is THE TIME ... !

The club supports local children’s charities by donating money made from the sale of crafts donated by its members at 3-5 locations yearly. The sales are over for 2022. Our first event for 2023 is the Crawfish Festival on Saturday, May 6<sup>th</sup> in Clinton Square. This event could be huge for us but we need to make sure we have enough product to sell. And, it would be really cool if we had some items that relate to the Crawfish Festival.

People ask what they can donate. Most anything is happily accepted. We received 4 music boxes before the Manlius Show and they were gone by noon on Saturday. Here are some of the typical items we are looking for in non-ornaments, scrolled, and turned. Carved? Always looking for items. Woodworkers ... Small boxes are one idea and I know there are others!

### Non-Ornament Items:

Small Cars/Trucks/Planes, etc.	Small Vases/Weed Pots	Candlestick/Tea Light Holders	Ice Cream Scoops	Small Cutting Boards
Small Puzzles	Pens	Rattles	Wizard Wands	Magnets
Small Boxes	Small Clocks	Seam Rippers	Letter Openers	Screw Drivers
Light Pulls	Keychains	Ring Holders	Magnets	Yo-Yos
Small Bowls	Various Kitchen Ware	Magnifiers	Kaleidoscopes	Snowmen

**Scrolled Ornaments:** Most any ornaments are welcome. We have plenty of smaller flat crosses. We need a variety of flat scrolled ornaments like:

Angels, Santas, Elves, Snowmen, & Other Holiday Related	Transportation Images like Trains, Planes, Cars	Service Groups like Firemen, Policemen, EMS, & All Military Branches
Birds like Hummingbirds, Cardinals, Eagles, Owls, Penguins, Chickadees, etc.	Fish, Bugs, Ladybugs, Butterflies, Flowers, Trees (Palm Tree), Other Flora, Whales, Shark, Octopus, etc.	Animals like Horses, Dogs, Cats, Elephants, Lions, Bears, Koala Bears, Hedgehogs, Dinosaurs, Dragons, Tigers
Sports esp. <i>non-standard</i> ones like Lacrosse, Snowboarding, Cycling, Wrestling, Volleyball, Ballet, Dance, Fencing, Sailing, Field Hockey, Crew, but also Baseball, Basketball, Football, Soccer, Field Hockey, Cycling, Hockey, Skiing, Running, Golf, Gymnastics, etc.		

### Turned Ornaments – Here are a few ideas:

Sea Urchins	Hollow Balls with Finials	Bird Houses
Angels	Light Bulbs of Multiple Sizes	Small Lighthouses
Drums, Bells	Trains	Snowmen of All Types & Shapes <i>Can Stand Alone or Hang as an Ornament</i>
Lollipops	Ice Cream Cones	Acorns, Mushrooms
Gnomes/Gonks	Trees—regular & windswept	Sleds with People On

**Holiday-Related Items** – We need multi-piece nativity scenes. We need larger crosses (6-12”) and have plenty of smaller ones. We need angels. We could use items depicting the 12 days of Christmas, esp. *Partridge in a Pear Tree*. We only have dreidels for patrons of the Jewish faith.

**Making Small Toys?** Consider leaving them unfinished and providing a cheap paint set or crayons for the kids to decorate their own!

## LOCATION OF MEETINGS

As some of you know, there is an issue between the Belgium Cold Springs Fire District Board of Fire Commissioners (BOFC) and Charlie and Barbara. The club has met free at Belgium Station 1 because Charlie is a member of the Department. Newly issued restrictions on the use of the Community Room have impacted our ability to meet at the firehouse. Straight answers are difficult to obtain from the BOFC. We are holding the April Woodworking and Turning SIG meetings at Canton Woods Senior Center which costs us money. As a newly elected Fire Commissioner, Charlie is working to resolve the issue with the other Commissioners but as of now, we will not be using the facility again in 2023.

The Scrolling SIG session will meet in April at Eight Acres and via Zoom. Board meetings are currently via Zoom. The Carving SIG continues to meet at Beaver Lake Nature Center.

The Board of Directors is appealing to our membership to identify other locations where we could meet in the future. Obviously, we would prefer to stay at the firehouse but the current climate there is not very welcoming despite the club's past donations and both Charlie and Barbara's ongoing contributions to the department. If you have ideas, please send to [woodcny@gmail.com](mailto:woodcny@gmail.com). In the meantime, be very aware of meeting locations identified in the newsletter and on the website. The website is the most current. If you have questions, please ask.



## SENDING PHOTOS

We love photos of your projects! We use them for this newsletter, for the online *Show & Tell*, for our website, and for our club slide show.

### HOW DO YOU SEND PHOTOS? HERE ARE THREE (3) WAYS:

**Send the Photo by Email** to the club email: [woodcny@gmail.com](mailto:woodcny@gmail.com). Add any additional information in the email that tells others about your project.

**Text the Photo** to Barbara's cell (315-345-5381) along with information. Remember, be sure to identify yourself!

**Got Lots of Photos?** Use a free product called **WeTransfer** [here](#) to send multiple photos. You can also use the *WeTransfer* app from your phone.

### WHAT ELSE SHOULD I SEND WITH PHOTOS?

With your photos, please send information about the projects shown in the photos – a brief description that should include wood used, finish, and any other information that makes it unique, even stories about the photos.



## FINDING EQUIPMENT/SUPPLIES LOCALLY

**AJ SAFETY & SUPPLIES**, 1859 Lemoyne Ave, Syracuse (former Syracuse Industrial Sales Building). 315-478-5751 Website is [ajsafetyproducts.com](http://ajsafetyproducts.com)

**MCQUADE & BANNIGAN**, 6300 East Molloy Rd, East Syracuse. 315-671-4400 (their primary office is in Utica 315-724-7119 and they have an office in Watertown 315-788-2612 Website is [mqb.com](http://mqb.com))

**GRAINGER INDUSTRIAL SUPPLY**—Syracuse Branch, 6285 Molloy Rd, East Syracuse. 800-472-4643 Website is [grainger.com](http://grainger.com)

**RUMETCO SALES**, 610 Bear St West, Syracuse. 315-422-0237

**HIAWATHA FASTENERS**, 6312 East Taft Road, North Syracuse. 315-452-0033



## Need Sandpaper or Other Supplies?

Call Charlie to Schedule a Time to Visit Eight Acres to Purchase or Come on Workshop Days



# CORPORATION SUPPLIES, LOANS, & SALES

## CONSUMABLES FOR SALE:

- ◆ **Ikea Ice Cream Scoops** \$5 each
- ◆ **White Abrasive Pads** (1200-1600 grit) [for applying finishes like Osmo] \$2 each
- ◆ **4 x 1/4" Pan Head Screws**—perfect for use with sawtooth hangers—Bag of 20 for \$1.25
- ◆ **Sawtooth Hanger**—9/16"x5/16" or 7/8"x5/16"
  - ◆ Bag of 10 for \$0.50
- ◆ **Miniature Drill Bits**
  - ◆ 1/16" (#52), 3/64" (#56), & 1/32" (#68)
  - ◆ 10 per package—\$6.50 per package
- ◆ **Drill Chuck Adapter for Miniature Bits**
  - ◆ \$11 each
- ◆ **Screw Eyes**—bag of 100 is \$1
- ◆ **Carborundum Sandpaper Sheets**
  - ◆ 80, 100, 120, 180, 240, 320, 400, 600, 800, and 1000 grit
  - ◆ \$1 per sheet or 6 sheets for \$5
- ◆ **Carborundum Sanding Pads—\$2 per pad**
  - ◆ Grits – medium (120-180), fine (320-400), superfine (500-600), ultrafine (800-1000), & microfine (1200-1500)
- ◆ **Sanding Discs from Woodturners Wonders**—bags priced
  - ◆ Purple in 1", 2" or 3"
  - ◆ Wonder Weave in 2" or 3"
  - ◆ Green Wave Oversized in 2"
    - ◆ Packaged in bags or 5 of lower grits: 60, 80, 120, 180, 240, 320, 400, & 600 or higher: 800, 1200, 1500, 2000, & 3000
- ◆ **Sanding Pad Holder Kits & Rolac Kits**
  - ◆ 2" & 3" sizes—bags priced
- ◆ **Anchor Seal**
  - ◆ Seals end grain of green wood to encourage slower drying
  - ◆ \$12 per gallon jug **New Price 4/1/2023**

- ◆ Available at meetings if you call Charlie LaPrease (315-720-7151) one day ahead
- ◆ Also available at Eight Acres by apmt.

NOTE: All prices include sales tax which the Corporation pays on an annual basis to New York State.

## TOOL LOAN PROGRAM

The Corporation owns a variety of equipment that members can borrow of a **maximum of one (1) month** at a time. This program is a way for beginners—or even seasoned woodworkers—to experiment with tools before purchasing. Some tools are stored at the Eight Acres Workshop while others, like the carving tools, are not. If you have an interest in borrowing tools, please send an email to [woodcny@gmail.com](mailto:woodcny@gmail.com). Your request will be directed and answered as appropriate.

With recent donations by members, we are expanding our collection of traditional tools and will be making more of those available for loan or even use at Eight Acres during both workshops and times scheduled with Charlie. Need something? Please ask!

## BOOK LOAN PROGRAM

The club has a mini-library with these and other titles:

- ◆ *Hogbin on Woodturning* by Stephen Hogbin
- ◆ *Woodburning with Style* by Simon Easton
- ◆ *Learn to Turn* by Barry Gross
- ◆ *O'Donnell's Woodturning Techniques* by Michael O'Donnell
- ◆ *Pen Turner's Workbook* by Barry Gross
- ◆ *Woodturning Chessmen* by Mike Darlow
- ◆ *Woodturning Methods* by Mike Darlow
- ◆ *Woodworker's Guide to Turning* (Back to Basics)

Do you have books you want to donate? Bring them to Michelle at any Turners meeting.

## SHARPENING SERVICES

Where can you get table saw blades and other tools sharpened?

**Ken of All Around Sharpening Services** is located in Jordan but you can drop off your items for sharpening at the Baldwinsville Supply which is at 82 East Genesee St (aka Rt 31, just east of the railroad tracks). Ken's cell phone is (315) 689-3184. Email is [sharpeningguy@twcny.rr.com](mailto:sharpeningguy@twcny.rr.com).

**Paul E. Hart** runs a service at 118 Fish Road, Mexico, NY 13114. The phone number is (315) 936-1880. Drop box at new address but picks up blades, etc. at Wiley Lumber & Doow Lumber in East Syracuse as well as Tracy Lumber & Ace Hardware in Fayetteville.



## AMERICAN ASSOCIATION OF WOODTURNERS

### WHY SHOULD I JOIN?

You enjoy woodturning and want more. Your club, the Woodworkers of Central New York, is a chapter of the American Association of Woodturners – AAW. What does that mean for you as a member of our club?

AAW offers the club officers access to a variety of resources from the AAW to help manage the club, including a negotiated reduced price for our corporation's liability insurance. We pay nothing else to AAW to be a chapter.

So what's in it for you? There are many great tools available to you as a member of AAW. You can explore the AAW website to learn about all

the resources you receive with your membership. Two of the biggest is the bi-monthly journal, *American Woodturner*, and the online only product, four issues of *Woodturning FUNDamentals*.

**What's the Cost? \$68 per year**

That's the cost if you want to receive a physical journal. If not, pay \$56 per year.

For each family member (associate), you pay an additional \$5.

Students aged 10-25 pay just \$34 annually for their membership

Join Today [here!](#)



## IN-PERSON WOODWORKING CLASSES

We are listed a few of the "local" craft/woodworking schools that hold classes on a variety of topics. As usual, checking a organization's website and/or calling the is the best way to verify class availability.

### Adirondack Folk School

Lake Luzerne, New York

[www.adirondackfolkschool.org](http://www.adirondackfolkschool.org)

### Appalachian Center for Craft

Smithville, Tennessee

[www.tntech.edu/fine-arts/craftcenter](http://www.tntech.edu/fine-arts/craftcenter)

### Arrowmont School of Arts & Crafts

Gatlinburg, Tennessee

[www.arrowmont.org](http://www.arrowmont.org)

### Connecticut Valley School of Woodworking

Manchester, Connecticut

[schoolofwoodworking.com](http://schoolofwoodworking.com)

### Florida School of Woodwork

Tampa, Florida

[schoolofwoodwork.com](http://schoolofwoodwork.com)

### John C. Campbell Folk School

Brasstown, North Carolina

[folkschool.org](http://folkschool.org)

### Marc Adams School of Woodworking

North Franklin, Indiana

[www.marcadams.com](http://www.marcadams.com)

### Pocosin Arts School of Fine Craft

Columbia, North Carolina

[pocosinarts.org](http://pocosinarts.org)

### Snow Farm / The NE Craft Program

Williamsburg, Massachusetts

[www.snowfarm.org](http://www.snowfarm.org)

### The Woodright's School

Roy Underhill's school

Pittsboro, North Carolina

[www.woodwrightschool.com](http://www.woodwrightschool.com)

### The Woodworking School at Pine Croft

Connected with Berea College; the former Kelly Mehler school

Berea, Kentucky

[pinecroftwoodschool.com](http://pinecroftwoodschool.com)

Do you know of other schools?

Please send the information to [woodcny@gmail.com](mailto:woodcny@gmail.com).



## CLASSES, EVENTS, & SYMPOSIUMS

### REGIONAL CLUB ACTIVITIES

#### Finger Lakes Woodturners

Meetings of the Finger Lakes Woodturners are a combination of in-person and remote demonstrations. They generally hold their meetings on the 3<sup>rd</sup> Thursday of the month and events are held in the shop space at **St. Michael's Workshop, 691 St. Paul St, Rochester**. Their website is: [Here](#).

In May, the Finger Lakes group is hosting **John Beaver** for a combination all-day demonstration on Saturday, May 20<sup>th</sup> and then three workshops on May 21-23. John will demo **bangles, protruding form, and round bottom bowls** on the 20<sup>th</sup>. The 3 workshops will feature different topics. The first on May 21<sup>st</sup> will cover **Bangles**. The second on May 22<sup>nd</sup> will cover the **Basic Wave Bowl and the Round Bottom Bowl**. The third on May 23<sup>rd</sup> will cover **Protruding Forms**. The price of the all-day demo is \$40 or \$58 with lunch. The prices on the workshops vary from \$140 to \$165 and do not include lunch but do include a materials fee. Go to their website to register and pay for each event. This is a great opportunity to learn from another great demonstrator!

#### Rochester Woodworkers Society

The Rochester Woodworkers Society host a variety of events on an ongoing basis. On May 13th, the group is heading to East Aurora for a two-part tour. First, from 10-12 attendees will tour Certainly Wood, an incredible veneer merchant with the opportunity to purchase veneer at a 30% discount during the tour. Following that tour, attendees will head to the Roycroft Inn for a lunch buffet and museum tour.

Check their website for more information and to register – [RWS Website](#)

### OTHER EVENTS OF INTEREST

#### 2023 American Association of Woodturners Symposium

June 1-4, Louisville, KY

Website: [here](#)

#### Northeast Woodcarvers Roundup 2023

July 16-20, Cherry Ridge Campsite, Honesdale, PA Website: [here](#)

#### Midwest Scroll Saw & Woodworking Trade Show

August 4-5, Dubuque County Fairgrounds, Iowa—Facebook Page: [here](#)

#### Mystic Woodcarvers present Woodcarvers Retreat of New England

September 15-18, Wisdom House, Litchfield, CT Website: [here](#)

Instructors include Mike Bloomquist, Ed Bracket & Harold Kaltenbach

#### Mid-Atlantic Woodturners Symposium

September 22-24, Marriott, Lancaster, PA

Website: [here](#)

Demonstrators are Simon Begg, Jason Breach, Roberto Ferrer, Kristen Levier, Eric Lofstrom, and Neil Turner

#### Northeast Woodcarvers Fall Carve-In

September 22-24, Cherry Ridge Campsite, Honesdale, PA Website: [here](#)

## DIRECTIONS TO EVENT LOCATIONS

Always check the website to identify the location of events. It has the latest information. Club Workshops are held at the *Eight Acres Event Center*, a private home near the North Area YMCA, east of Baldwinsville, NY. The address is available by request: [woodcny@gmail.com](mailto:woodcny@gmail.com)

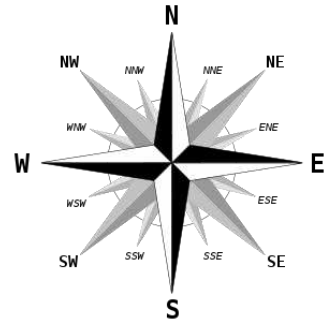

### CARVERS DEMONSTRATIONS/EVENTS

The Carvers meet in the large Community Room at the **Beaver Lake Nature Center, 8477 East Mud Lake Road, Baldwinsville, NY.**

The Nature Center is located west of the Village of Baldwinsville and west of Route 690 North. Mud Lake Road is about 1 3/4 miles west from the 690 exit ramp for Route 370. There is an animal hospital just past Mud Lake Road across the street. The entrance to the park is about 1/3 of a mile from your turn onto Mud Lake Road.

The entrance is on the left. Follow the roadway in, wait for the traffic arm to raise and park in either of the lots. Walk to the main building, enter, turn right, and then right again into the large room.

After meetings end, your will exit by the same roadway. If the traffic arm is down, buzz the desk and tell who answers you are with the carvers. They will lift the gate for you to drive through. There is no charge for parking.

### WOODWORKERS & TURNERS DEMONSTRATIONS/EVENTS

Demonstrations & events will be held at the Canton Woods Senior Center, 76 Canton Street, Baldwinsville, NY.

The Center is in the Village but on the south side of the River off Downer Street which is Rt 31.

From Rt 690 North/South, you take the exit for Downer St/Route 31 and

head east 1.1 miles and turn right onto Canton St. The Center is on the right about 1400 feet south.

From the center of the Village (the 4 corners) where Rts 370/31 meet Rt 48, turn left south onto Rt 48. At the second traffic light, turn right onto Downer St and make the next left onto Canton St.

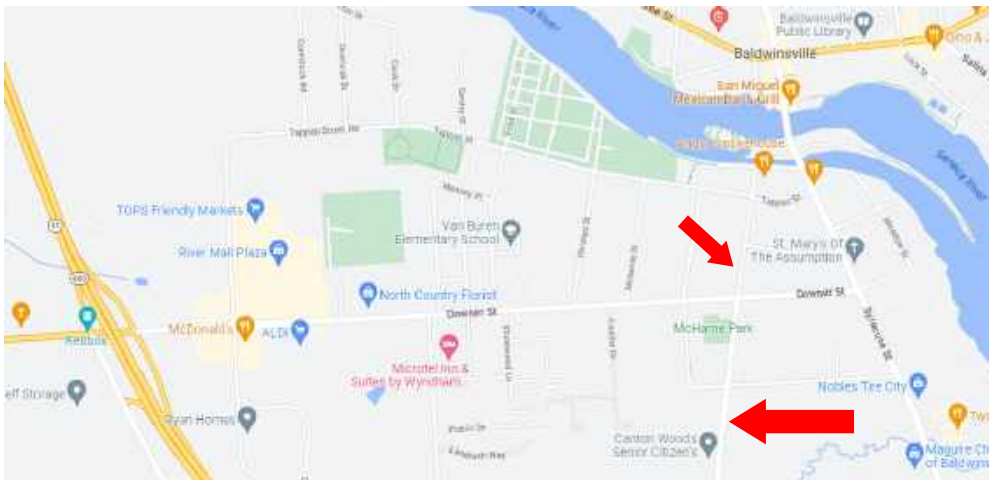

The Scrolling SIG will be in the club workshop at *Eight Acres* for now. Meetings will also be available via Zoom. Members will receive the address of the workshop via email ahead of the meeting or they can request via an email to [woodcny@gmail.com](mailto:woodcny@gmail.com).

See Right

### SCROLLERS DEMONSTRATIONS/EVENTS



*Schedules subject  
to change*

## MEETINGS SCHEDULES

### WOODWORKERS SIG SPONSORED DEMOS—2023

Date	Topic	Demonstrator/Speaker
January 4 <sup>th</sup>	<b>Dust Collection</b>	Oneida Air
February 1 <sup>st</sup>	<b>Air Brushing, the Basics</b>	Jackie Yonkers
March 1 <sup>st</sup>	<b>Kumiko, the Basics</b>	David Wheat & Tom Clooney
April 5 <sup>th</sup>	<b>CPR: What You Need to Know</b>	Janelle Melchior
May 3 <sup>rd</sup>	<b>Photographing Your Projects</b>	Dan Ware
June 7 <sup>th</sup>	<b>“Alignment with the Stars”</b>	Bruce Meissner, Doug North & Charlie LaPrease
July 5 <sup>th</sup>		
August 2 <sup>nd</sup>		
September 6 <sup>th</sup>		
October 4 <sup>th</sup>		
Saturday, November 11 <sup>th</sup>	17 <sup>th</sup> Woodworkers Challenge <i>All Members Plan to Participate in this Annual Competition!</i>	
Sunday in December	<i>Holiday Event — One Party for All Members</i>	

### TURNERS SIG SPONSORED DEMOS—2023

Date	Topic	Demonstrator	Workshop
January 10 <sup>th</sup>	<b>Turning a Snowman &amp; Tree</b>	Ray Smith	January 14
February 14 <sup>th</sup>	<b>Tool Fundamentals</b>	Robert Love, etc.	February 18
March 14 <sup>th</sup>	<b>Turning a Bowl</b>	Charlie LaPrease	March 18
April 11 <sup>th</sup>	<b>Turning a Whiskey Cup</b>	Dave Grant	April 15
May 9 <sup>th</sup>	<b>Turning Boxes with Threaded Lids</b>	Jim Kent	May 13
June 13 <sup>th</sup>	<b>N-Loop Celtic Knots IRD</b>	Alan Stratton	June 17
July 11 <sup>th</sup>	<b>Making a Paper Towel Holder</b>	Mark Anastas	July 15
August 8 <sup>th</sup>			August 12
September 12 <sup>th</sup>	TBD	Ed Siegel	September 16
October 10 <sup>th</sup>			October 14
Saturday November 11 <sup>th</sup>	17 <sup>th</sup> Woodworkers Challenge <i>All Members Plan to Participate in this Annual Competition!</i>		November 18
Sunday in December	<i>Holiday Event — One Party for All Members</i>		

Continued on Page 33

## MEETINGS SCHEDULES

Schedules subject to change

### CARVERS SPONSORED DEMOS/CLASSES—2023

Date	Topic
January 19 <sup>th</sup>	<b>Carving a Valentine Heart</b> w/ Gary Morison
February 16 <sup>th</sup>	<b>Carving Hearts</b> — Part 2 w/Gary Morison
March 16 <sup>th</sup>	<b>Sharpening Carving Tools</b> —w/Dave Weir
April 20 <sup>th</sup>	<b>Shroomspirit</b> w/Mike Bloomquist
May 18 <sup>th</sup>	<b>Shroomspirit</b> — <b>Part 2</b> w/Mike Bloomquist
June 10 & 11	<b>Face Carving Workshop</b> with Jim O’Dea or <b>Quilted Stocking Workshop</b> with Chris O’Dea [Fee TBD]
June 15 <sup>th</sup>	<b>Making a Knife Handle</b> w/Gary Morison
July 27 <sup>th</sup>	<b>Mushroom Gnome House</b> w/Harold Kaltenbach
August 17 <sup>h</sup>	<b>Mushroom Gnome House</b> — <b>Part 2</b> w/Harold Kaltenbach
September 21 <sup>st</sup>	<b>Rolling Bear</b> with Frank Huckabone
October 19 <sup>th</sup>	<b>Carved Rose</b> w/Sam Lupo
Saturday, November 11 <sup>th</sup>	<b>17th Woodworkers Challenge</b> <i>All Members Plan to Participate in this Annual Competition!</i>
November 17 <sup>th</sup>	<b>Carved Rose</b> — <b>Part 2</b> w/Sam Lupo
Sunday in December	<i>Holiday Event — One Party for All Members</i>
December ??	Unfinished Project Workshop & Holiday Party

### SCROLLERS SIG SPONSORED DEMOS—2023

**NOTE:** Due to a combination of factors, the Scrolling SIG will hold its in-person meetings in the club workshop space at Barb & Charlie’s. We will continue to employ Zoom to broadcast those meetings for our remote members. All are welcome to attend these sessions.

Date	Topic
February 15 <sup>th</sup>	<b>Intarsia</b> w/Sherry — Challenge: Segmented Project
April 19 <sup>th</sup>	<b>Back to the Basics</b> — Challenge: Intarsia Project
June 21 <sup>st</sup>	<b>Using Spiral Blades</b> — Challenge: Christmas Ornaments
July & August	<b>No Meetings—Get Your Projects in For NYS Fair Competition!</b>
September 20 <sup>th</sup>	<b>Undulating Ring Baskets/Simulated Baskets</b> — Challenge: Spiral Blade Project
October 19 <sup>th</sup>	<b>Scrollsaw Joinery</b> — Challenge: Baskets
Saturday, November 11 <sup>th</sup>	<b>17th Woodworkers Challenge</b> <i>All Members Plan to Participate in this Annual Competition!</i>
Sunday in December	<i>Holiday Event — One Party for All Members</i>

**Classifieds are welcome with the caveat that people notify the editor when entries are sold.**

**\*\* MEMBER OF CLUB**

Also, see various offerings by members in the classifieds above as well as the links on the Wood ID & Suppliers page on the website.

## CLASSIFIEDS

**FREE—Old Rockwell-Delta Floor Model Drill Press** with 1/2" chuck in working order. Call Clarence (Fibber) Magee @516-524-1382 or at fibber.magee@gmail.com. Located outside of Greene, NY. *Going to junk if no one wants!*

**FREE— 8 Foot Long T2 Single Pole Fluorescent Tubes** (Qty 12) - Used but still working. Contact George Loreface at 315-427-1623 or [loreficegi@gmail.com](mailto:loreficegi@gmail.com)

**FOR SALE—Grizzly 2HP Dust Collector**—steel impeller. \$400. Contact Kevin Rawlings at [hostaguy@gmail.com](mailto:hostaguy@gmail.com)

**FOR SALE—General 3HP Shaper Model 40-250 (220V)** with accessories. Original owner. \$1500. Contact Rick Simmons at [rick2859@yahoo.com](mailto:rick2859@yahoo.com) or 315-876-8338

**WANTED—DRY, Live Edge Hardwood Boards.** Minimum size of 5 inches wide, 12 inches long, and at least 1½" thick. Wider and longer the better. Contact Mel Taber at (315) 487-7855 or [mtaber3@gmail.com](mailto:mtaber3@gmail.com).

**FOR SALE — Used bench vises.** Good quality, commercial grade. Price \$50 to \$75 each. For more info, email **Bud Millis** at (315) 297-7525/[emillis@twcny.rr.com](mailto:emillis@twcny.rr.com)

**FOR SALE — LUMBER – Kiln & Air Dried Hardwoods** (PA cherry, chestnut, maple, white oak, butternut, etc.) and some softwoods available. Also Black Walnut and English Walnut slabs available. Contact **Bud Millis** at (315) 297-7525 or [emillis@twcny.rr.com](mailto:emillis@twcny.rr.com).

## AREA LUMBER SUPPLIERS

**Custom Hardwood Lumber Co.** 8633 State Route 104  
Hannibal, NY 13074  
(315) 564-3101 Facebook link [here](#)  
[Customhardwoodlumber@gmail.com](mailto:Customhardwoodlumber@gmail.com)

**Dexters Woodshop**  
6949 Kingdom Rd  
Memphis  
(315) 456-8271

**Logs to Lumber**  
720 Church St, Baldwinsville  
(315) 678-2151

**Memphis Hardwood Lumber**  
6535 Church St, Memphis (315) 689-3949  
[www.memphishardwoodlumber.com](http://www.memphishardwoodlumber.com)

**Lakeshore Hardwoods \*\***  
266 Manwaring Rd., Pulaski (315) 298-6407  
191 West Main St, Victor (585) 869-5118  
[www.lakeshorehardwoods.com](http://www.lakeshorehardwoods.com)

**Kennedy Hardwood**  
1939 Clark Rd., Preble (607) 749-7890  
[www.kennedyhardwood.com](http://www.kennedyhardwood.com)

**Liverpool Lumber Company**  
201 North Willow St., Liverpool  
(315) 457-2220  
[liverpool-lumber.com](http://liverpool-lumber.com)

**Pittsford Lumber**  
50 State St., Pittsford (585) 586-1877  
[www.pittsfordlumber.com](http://www.pittsfordlumber.com)

**Tracy Lumber [B.H. Tracy & Sons]**  
550 East Genesee St., Fayetteville  
(315) 637-3174  
[www.tracylumber.com](http://www.tracylumber.com)

**Willey Lumber Company**  
100 Hartwell Ave, East Syracuse  
(315) 437-3344  
[www.willeylumber.com](http://www.willeylumber.com)

**Johnson Brothers Lumber**  
2550 Ballina Rd, Cazenovia (315) 655-8824  
[www.johnsonbrotherslumber.com](http://www.johnsonbrotherslumber.com)

**Salt City Woods, Mill & Kiln**  
1153 West Fayette St  
Syracuse, NY 13204  
(315) 952-1692  
[derby@saltcitywoods.com](mailto:derby@saltcitywoods.com)  
[saltcitywoods.com](http://saltcitywoods.com)

*May have moved to Old Liverpool Rd. facility. Call first.*

**Brown Dog Wood Products**  
1379 County Route 4, Central Square  
315-243-8358  
[www.Browndogwoodproducts.com](http://www.Browndogwoodproducts.com)